

Operating Manual

Document Scanner

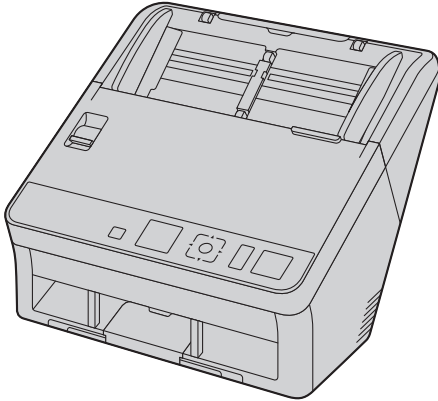

Model No.	KV-S1058Y	
	KV-S1028Y	
	KV-S1057C	M2
	KV-S1027C	M2
	KV-S1057C	J2
	KV-S1027C	J2
	KV-S1057C	B2
	KV-S1027C	B2

These instructions contain information on operating the scanner. Before reading these instructions, please read the Quick Installation Guide enclosed with this unit.

Keep all documentation in a safe place for future reference.

Current model availability depends on your country/area. Please contact your dealer.

KV-S1057C / KV-S1027C only:

- The scanner may be displayed on your computer as the "KV-S1057C MK2" / "KV-S1027C MK2".
- When you download the driver from web site, download the driver for "KV-S1057C MK2" / "KV-S1027C MK2".

Introduction

Thank you for purchasing a **Panasonic Document Scanner**.

Trademarks

- Microsoft, Windows, Windows Vista, SharePoint and Internet Explorer are either registered trademarks or trademarks of Microsoft Corporation in the United States and/or other countries.
- ISIS is a registered trademark or trademark of EMC Corporation in the United States and/or other countries.
- IBM® is a trademark of International Business Machines Corporation, registered in many jurisdictions worldwide.
- Intel® and Intel Core™ are trademarks of Intel Corporation or its subsidiaries in the U.S. and/or other countries.
- Adobe® and Reader® are either registered trademarks or trademarks of Adobe Systems Incorporated in the United States and/or other countries.
- Google® and Google Chrome™ are either trademarks or registered trademarks of Google LLC.
- Mozilla® and Firefox® are registered trademarks of the Mozilla Foundation.
- Bonjour is a trademark of Apple Inc., registered in the U.S. and other countries.
- All other trademarks identified herein are the property of their respective owners.

About the Descriptions in This Manual

- Windows refers to the Microsoft Windows operating system (hereafter Windows).
- Windows Vista refers to the Microsoft Windows Vista operating system (hereafter Windows Vista).
- The screen shots used in this manual may differ from the screens displayed on your computer.
- Letter size: This is the standard paper size of 8.5 in. × 11 in. used in the United States and/or other countries.
- A4 size: This is a standard paper size of 210 mm × 297 mm.
- dpi (dots per inch): This is the number of dots per inch. This unit is used for scanning and printing resolution. The higher the dpi value is, the higher the resolution becomes.
- lb.: "Weight in pounds" of paper represents the weight of 500 (432 mm × 559 mm [17 in. × 22 in.]) sheets.

Note

- Locations represented with page numbers in () include a link to that location. When using Adobe Reader (version 11), if you press the [Alt] key and the [←] key at the same time after moving to a referenced page, you can return to the previous page. For details about using Reader, see the Reader help.

About the Documentation

The scanner documentation consists of 2 manuals: the Operating Manual (this manual), and the Quick Installation Guide.

Operating Manual (this manual)	This manual provides information about the operation of the unit.
Quick Installation Guide	The Quick Installation Guide explains about safety precautions and other important information, and outlines brief installation procedures of the unit and software.

About the Software Help

Each software contains help files.

For details about viewing the help files, see "4.4.2 To view the help" (page 24).

Software / Manual CD-ROM Contents

Drivers	Device Driver
	TWAIN ^{*1}
	ISIS ^{*1}
Applications	Image Capture Plus ^{*1*2}
Utilities	User Utility ^{*1}
	Scan Button Setting Tool ^{*3}
	Scan Server Setting Tool ^{*4}
	Network Scanner Select Tool ^{*4}
	Network Setting Tool ^{*5}
Export Import Tool ^{*6}	
Documents^{*7}	Operating Manual
	Control sheet ^{*8}

*1 USB connected scanner or selected scanner by "Network Scanner Select Tool" can communicate.

*2 Image Capture Plus is a Panasonic original application for configuring advanced scanning settings.

*3 This tool is used when the scanner is connected via USB.

*4 This tool is used when the scanner is connected over a LAN.

*5 This tool is used to configure the scanner for use over LAN connection. To make these settings, connect via USB.

*6 This tool is used to copy the settings of various software on the PC to another PC.

*7 Each document is a PDF document. To view documents correctly, install Adobe Reader.

*8 For details about the control sheet, see "6.3.4 Using Control Sheets (ADF)" (page 52).

System Requirements

Computer	IBM PC/AT or compatible machine with a CD-ROM drive
CPU	Intel Core 2 Duo 1.8 GHz or higher
Interface	USB 2.0 / USB 3.0 / USB 3.1 LAN (10Base-T / 100Base-TX / 1000Base-T)
Recommended web browser	Internet Explorer 11 / Mozilla Firefox (latest version) / Google Chrome (latest version)

Note

- For details about the system requirements, refer to [Read me first] in the Software / Manual CD-ROM.
- The scanning speed differs depending on the host computer's operating environment or the application used.
- Due to the slower speed of USB 1.1, it is recommended to use a USB 2.0 / USB 3.0 / USB 3.1 interface.
- If you connect the unit to a USB hub, it is not guaranteed to work.

Copyright and license information

Software license for SNMP protocol

This product contains Net-SNMP software and uses it based on the following license conditions.

---- Part 1: CMU/UCD copyright notice: (BSD like) ----

Copyright 1989, 1991, 1992 by Carnegie Mellon University

Derivative Work - 1996, 1998-2000

Copyright 1996, 1998-2000 The Regents of the University of California

All Rights Reserved

Permission to use, copy, modify and distribute this software and its documentation for any purpose and without fee is hereby granted, provided that the above copyright notice appears in all copies and that both that copyright notice and this permission notice appear in supporting documentation, and that the name of CMU and The Regents of the University of California not be used in advertising or publicity pertaining to distribution of the software without specific written permission.

CMU AND THE REGENTS OF THE UNIVERSITY OF CALIFORNIA DISCLAIM ALL WARRANTIES WITH REGARD TO THIS SOFTWARE, INCLUDING ALL IMPLIED WARRANTIES OF MERCHANTABILITY AND FITNESS. IN NO EVENT SHALL CMU OR THE REGENTS OF THE UNIVERSITY OF CALIFORNIA BE LIABLE FOR ANY SPECIAL, INDIRECT OR CONSEQUENTIAL DAMAGES OR ANY DAMAGES WHATSOEVER RESULTING FROM THE LOSS OF USE, DATA OR PROFITS, WHETHER IN AN ACTION OF CONTRACT, NEGLIGENCE OR OTHER TORTIOUS ACTION, ARISING OUT OF OR IN CONNECTION WITH THE USE OR PERFORMANCE OF THIS SOFTWARE.

---- Part 2: Networks Associates Technology, Inc copyright notice (BSD) ----

Copyright (c) 2001-2003, Networks Associates Technology, Inc

All rights reserved.

Redistribution and use in source and binary forms, with or without modification, are permitted provided that the following conditions are met:

- Redistributions of source code must retain the above copyright notice, this list of conditions and the following disclaimer.
- Redistributions in binary form must reproduce the above copyright notice, this list of conditions and the following disclaimer in the documentation and/or other materials provided with the distribution.
- Neither the name of the Networks Associates Technology, Inc nor the names of its contributors may be used to endorse or promote products derived from this software without specific prior written permission.

THIS SOFTWARE IS PROVIDED BY THE COPYRIGHT HOLDERS AND CONTRIBUTORS ``AS IS'' AND ANY EXPRESS OR IMPLIED WARRANTIES, INCLUDING, BUT NOT LIMITED TO, THE IMPLIED WARRANTIES OF MERCHANTABILITY AND FITNESS FOR A PARTICULAR PURPOSE ARE DISCLAIMED. IN NO EVENT SHALL THE COPYRIGHT HOLDERS OR CONTRIBUTORS BE LIABLE FOR ANY DIRECT, INDIRECT, INCIDENTAL, SPECIAL, EXEMPLARY, OR CONSEQUENTIAL DAMAGES (INCLUDING, BUT NOT LIMITED TO, PROCUREMENT OF SUBSTITUTE GOODS OR SERVICES; LOSS OF USE, DATA, OR PROFITS; OR BUSINESS INTERRUPTION) HOWEVER CAUSED AND ON ANY THEORY OF LIABILITY, WHETHER IN CONTRACT, STRICT LIABILITY, OR TORT (INCLUDING NEGLIGENCE OR OTHERWISE) ARISING IN ANY WAY OUT OF THE USE OF THIS SOFTWARE, EVEN IF ADVISED OF THE POSSIBILITY OF SUCH DAMAGE.

---- Part 3: Cambridge Broadband Ltd. copyright notice (BSD) ----

Portions of this code are copyright (c) 2001-2003, Cambridge Broadband Ltd.

All rights reserved.

Redistribution and use in source and binary forms, with or without modification, are permitted provided that the following conditions are met:

- Redistributions of source code must retain the above copyright notice, this list of conditions and the following disclaimer.
- Redistributions in binary form must reproduce the above copyright notice, this list of conditions and the following disclaimer in the documentation and/or other materials provided with the distribution.
- The name of Cambridge Broadband Ltd. may not be used to endorse or promote products derived from this software without specific prior written permission.

THIS SOFTWARE IS PROVIDED BY THE COPYRIGHT HOLDER "AS IS" AND ANY EXPRESS OR IMPLIED WARRANTIES, INCLUDING, BUT NOT LIMITED TO, THE IMPLIED WARRANTIES OF MERCHANTABILITY AND FITNESS FOR A PARTICULAR PURPOSE ARE DISCLAIMED. IN NO EVENT SHALL THE COPYRIGHT HOLDER BE LIABLE FOR ANY DIRECT, INDIRECT, INCIDENTAL, SPECIAL, EXEMPLARY, OR CONSEQUENTIAL DAMAGES (INCLUDING, BUT NOT LIMITED TO, PROCUREMENT OF SUBSTITUTE GOODS OR SERVICES; LOSS OF USE, DATA, OR PROFITS; OR BUSINESS INTERRUPTION) HOWEVER CAUSED AND ON ANY THEORY OF LIABILITY, WHETHER IN CONTRACT, STRICT LIABILITY, OR TORT (INCLUDING NEGLIGENCE OR OTHERWISE) ARISING IN ANY WAY OUT OF THE USE OF THIS SOFTWARE, EVEN IF ADVISED OF THE POSSIBILITY OF SUCH DAMAGE.

---- Part 4: Sun Microsystems, Inc. copyright notice (BSD) ----

Copyright c 2003 Sun Microsystems, Inc., 4150 Network Circle, Santa Clara, California 95054, U.S.A. All rights reserved.

Use is subject to license terms below.

This distribution may include materials developed by third parties.

Sun, Sun Microsystems, the Sun logo and Solaris are trademarks or registered trademarks of Sun Microsystems, Inc. in the U.S. and other countries.

Redistribution and use in source and binary forms, with or without modification, are permitted provided that the following conditions are met:

- Redistributions of source code must retain the above copyright notice, this list of conditions and the following disclaimer.
- Redistributions in binary form must reproduce the above copyright notice, this list of conditions and the following disclaimer in the documentation and/or other materials provided with the distribution.
- Neither the name of the Sun Microsystems, Inc. nor the names of its contributors may be used to endorse or promote products derived from this software without specific prior written permission.

THIS SOFTWARE IS PROVIDED BY THE COPYRIGHT HOLDERS AND CONTRIBUTORS "AS IS" AND ANY EXPRESS OR IMPLIED WARRANTIES, INCLUDING, BUT NOT LIMITED TO, THE IMPLIED WARRANTIES OF MERCHANTABILITY AND FITNESS FOR A PARTICULAR PURPOSE ARE DISCLAIMED. IN NO EVENT SHALL THE COPYRIGHT HOLDERS OR CONTRIBUTORS BE LIABLE

FOR ANY DIRECT, INDIRECT, INCIDENTAL, SPECIAL, EXEMPLARY, OR CONSEQUENTIAL DAMAGES (INCLUDING, BUT NOT LIMITED TO, PROCUREMENT OF SUBSTITUTE GOODS OR SERVICES; LOSS OF USE, DATA, OR PROFITS; OR BUSINESS INTERRUPTION) HOWEVER CAUSED AND ON ANY THEORY OF LIABILITY, WHETHER IN CONTRACT, STRICT LIABILITY, OR TORT (INCLUDING NEGLIGENCE OR OTHERWISE) ARISING IN ANY WAY OUT OF THE USE OF THIS SOFTWARE, EVEN IF ADVISED OF THE POSSIBILITY OF SUCH DAMAGE.

Software license for SNMP protocol

This product also contains software which includes following notices and licenses.

Copyright 1988, 1989, 1990 by Carnegie Mellon University
Copyright 1989 TGV, Incorporated
All Rights Reserved

Permission to use, copy, modify, and distribute this software and its documentation for any purpose and without fee is hereby granted, provided that the above copyright notice appear in all copies and that both that copyright notice and this permission notice appear in supporting documentation, and that the name of CMU and TGV not be used in advertising or publicity pertaining to distribution of the software without specific, written prior permission.

CMU AND TGV DISCLAIMS ALL WARRANTIES WITH REGARD TO THIS SOFTWARE, INCLUDING ALL IMPLIED WARRANTIES OF MERCHANTABILITY AND FITNESS, IN NO EVENT SHALL CMU OR TGV BE LIABLE FOR ANY SPECIAL, INDIRECT OR CONSEQUENTIAL DAMAGES OR ANY DAMAGES WHATSOEVER RESULTING FROM LOSS OF USE, DATA OR PROFITS, WHETHER IN AN ACTION OF CONTRACT, NEGLIGENCE OR OTHER TORTIOUS ACTION, ARISING OUT OF OR IN CONNECTION WITH THE USE OR PERFORMANCE OF THIS SOFTWARE.

Software license for HTTPd protocol

This product contains thttpd software developed by ACMELabs and uses it based on the following license conditions.

Copyright 1995,1998,1999, 2000 by Jef Poskanzer <jef@acme.com>.
All rights reserved.

Redistribution and use in source and binary forms, with or without modification, are permitted provided that the following conditions are met:

1. Redistributions of source code must retain the above copyright notice, this list of conditions and the following disclaimer.
2. Redistributions in binary form must reproduce the above copyright notice, this list of conditions and the following disclaimer in the documentation and/or other materials provided with the distribution.

THIS SOFTWARE IS PROVIDED BY THE AUTHOR AND CONTRIBUTORS ``AS IS" AND ANY EXPRESS OR IMPLIED WARRANTIES, INCLUDING, BUT NOT LIMITED TO, THE IMPLIED WARRANTIES OF MERCHANTABILITY AND FITNESS FOR A PARTICULAR PURPOSE ARE DISCLAIMED. IN NO EVENT SHALL THE AUTHOR OR CONTRIBUTORS BE LIABLE FOR ANY DIRECT, INDIRECT, INCIDENTAL, SPECIAL, EXEMPLARY, OR CONSEQUENTIAL DAMAGES (INCLUDING, BUT NOT LIMITED TO, PROCUREMENT OF SUBSTITUTE GOODS OR SERVICES; LOSS OF USE, DATA, OR PROFITS; OR BUSINESS INTERRUPTION) HOWEVER CAUSED AND ON ANY THEORY OF LIABILITY, WHETHER IN CONTRACT, STRICT LIABILITY, OR TORT (INCLUDING NEGLIGENCE OR OTHERWISE) ARISING IN ANY WAY OUT OF THE USE OF THIS SOFTWARE, EVEN IF ADVISED OF THE POSSIBILITY OF SUCH DAMAGE.

Table of Contents

1	Feature Highlights	11
2	Before You Start	12
2.1	Precautions	12
2.2	Security Notice	14
2.2.1	Management of documents and scanned data	14
2.2.2	Management of setting information	14
2.3	Check the Accessories	15
2.3.1	Optional Accessories	16
3	Location of Controls	17
3.1	Main Unit	17
3.1.1	Front	17
3.1.2	Rear	18
4	Installation	19
4.1	Required Space Around the Scanner	19
4.2	Moving the Unit	20
4.3	Installing the Software	21
4.3.1	When using this unit with a USB connection	22
4.3.2	When using this unit with a wired LAN connection	23
4.4	Viewing Operating Manual and Help Installed	24
4.4.1	To view the Operating Manual	24
4.4.2	To view the help	24
5	Operation Panel	25
5.1	About LED	26
5.2	About LCD	27
5.3	Menu screen	28
6	Operation	31
6.1	Basic Operations	31
6.1.1	Turning ON/OFF the unit's power	31
6.1.2	Returning from sleep mode	31
6.1.3	Changing the language used on the LCD	31
6.1.4	Changing the date and time	31
6.1.5	Opening/Closing the ADF door	32
6.2	Preparing Documents for the ADF	33
6.2.1	About documents for the ADF	33
6.2.1.1	Compatible Paper	33
6.2.1.2	Compatible Card	35
6.2.1.3	Compatible Passport	35
6.2.1.4	Carrier sheet (KV-SS077)	36
6.2.1.5	Incompatible Documents	37
6.2.1.6	Notes about Documents for Scanning	38
6.2.1.7	Notes about Double Feed Detection	38
6.2.2	Loading documents on the ADF	39
6.2.2.1	When using the carrier sheet	44
6.3	Scanning Documents	46
6.3.1	Switching the Background Color of Scanned Images	46
6.3.2	Using Manual feeding	46
6.3.3	Mixed Batch Card Guide (ADF)	47

6.3.3.1	Installing the mixed batch card guide	47
6.3.3.2	Removing the mixed batch card guide	49
6.3.3.3	Using the Mixed Batch Card Guide	51
6.3.4	Using Control Sheets (ADF)	52
6.3.4.1	About Printing Control Sheets	53
6.4	Using Push Scan	54
6.4.1	Outline of Push Scan	54
6.4.2	Output File	55
6.4.3	USB mode	57
6.4.4	Network PC mode	59
6.4.5	Preset Scan mode	61
7	Scan Server	64
7.1	Functions that require a scan server	64
7.2	How to set up the scan server	65
8	Using Configuration Web	66
8.1	Launch Configuration Web	66
8.2	Basic Browser Operations	67
8.2.1	Available characters in Configuration Web	68
8.3	Information tab	69
8.4	Function tab	70
8.5	Scan tab	72
8.6	Network tab	74
8.7	Server tab	76
8.8	Administrator tab	78
9	Clearing Paper Jams	80
10	Care and Maintenance	82
10.1	Cleaning the Outside of the Scanner	82
10.2	Cleaning the Inside of the Scanner	83
10.2.1	Cleaning the Conveyor and Scanning Glasses	84
10.2.2	Cleaning the Double Feed Detectors and Starting Sensors	85
10.2.3	Cleaning the Rollers	86
10.2.4	Cleaning Mode	91
10.2.5	Clearing the Counter After Cleaning the Rollers	93
10.3	Replacing the Rollers	94
10.3.1	Clearing the Counter After Replacing the Rollers	100
11	Appendix	101
11.1	Available Functions When Scanning	101
11.2	Perform Network Settings with USB Connection	103
11.2.1	Configuring wired LAN settings	103
11.3	Check the Event Settings for Push Scan	105
11.4	Server Certificate	106
11.4.1	Installing a server certificate	106
11.4.2	Installing a self-signed certificate	107
11.5	Import/Export	108
11.6	Backup/Restore	109
11.7	Factory Reset	110
11.8	Troubleshooting	111
11.9	Error Codes and Error Messages	115
11.10	Uninstalling the Software	118
11.11	Repacking Instructions	119

11.12	Specifications	120
-------	----------------------	-----

1 Feature Highlights

Network Function

- This scanner can be connected directly to a network.

Preset Scan

- If you register scanning conditions in advance, you can scan directly to an FTP server, a shared folder, or e-mail without using a computer.

High-speed Double Sided Scanning

- This scanner can scan documents at high speed, regardless of the image type (monochrome / color).

Background Color Switching Function

- The background color of the scanned images can be switched between white and black.

Double Feed Detection Function

- Double feeding can be detected even if you scan documents that contain paper of various thicknesses.

Double Feed Skip (DFS) Function

- If the scanning process stops because documents (such as envelopes or receipts attached to documents) are being detected as double fed, the double feed skip (DFS) function can be used to resume scanning.

Push Scan

- If you register the scanning conditions for a job in advance, you can start scanning without operating the computer.

Card Scanning

- A maximum of 3 cards can be loaded on the feed tray.

Mixed Batch Card Guide

- A mixed batch card guide is available for scanning mixed media (cards and papers) at the same time.

Manual Feed Selector

- Bound documents can be scanned by setting the manual feed selector to manual feeding.

Other Features

- The paper feed path can be opened widely to easily remove jammed paper and perform maintenance.
- This scanner has a counter function which indicates approximately when cleaning and the replacement of rollers will be necessary. The counters can be configured and checked.

2 Before You Start

2.1 Precautions

Illegal Duplication

It is unlawful to make duplicates of certain documents.

Duplicating certain documents may be illegal in your country/area.

Penalties of fines and/or imprisonment may be imposed on those found guilty. The following are examples of items that may be illegal to duplicate in your country/area.

- Currency
- Bank notes and checks
- Bank and government bonds, and securities
- Passports, licenses, official or private documents, identification cards, and the like
- Copyright materials, or trademarks without the consent of the owner
- Postage stamps, and other negotiable instruments

This list is not inclusive, and no liability is assumed for either its completeness or accuracy. In case of doubt, contact your legal counsel.

Notice

Install your machine near a supervised area to prevent illegal duplication from being made.

Installation

- Do not place the unit in direct sunlight, in a cold draft, or near heating apparatus.
- Do not place the unit near apparatus which generate electronic or magnetic noise.
- Protect the unit from static electricity.
- Do not move the unit immediately from a cold place to a warm place. It may cause condensation, which may damage the unit. Using the unit immediately will cause the document scanning to be imperfect. To avoid this, clean the inside rollers with a dry and soft cloth, leave the unit in a warm place for 1 or 2 hours, and then use the unit after you make sure that the inside of the unit has dried.
- When the unit is not used over an extended period of time, turn the unit off, and unplug the power cord. The unit consumes approximately 0.3 W - 0.5 W of electricity even when the main unit is turned off.
- Use only the power cord and the USB cable that are provided with the unit.

CD-ROM

- Do not write or stick paper on the front and/or back of CD-ROM.
- Do not touch the data side of the CD-ROM. When handling the CD-ROM, be careful not to leave fingerprints or otherwise damage the CD-ROM.
- Do not leave the CD-ROM where it is directly exposed to sunlight or near a heater for extended periods.
- Do not throw or bend the CD-ROM.

Roller Cleaning Paper

Using a pair of scissors, open the bag along the dotted line (①), and take out the roller cleaning paper.

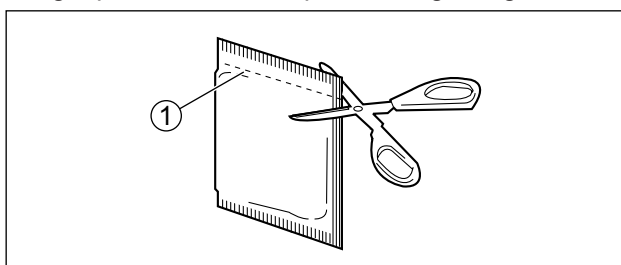

- Keep the roller cleaning paper out of reach of small children.
- Do not store the roller cleaning paper in direct sunlight or in a place with a temperature over 40 °C (104 °F).
- Only use the roller cleaning paper to clean the rollers.
- For details about the roller cleaning paper, please refer to the Safety Data Sheet (SDS). Please ask your Panasonic sales company about obtaining the Safety Data Sheet.
- If the bag is left opened for a long period of time before using it, the alcohol will evaporate. Please use the roller cleaning paper immediately after opening the bag.
- To purchase the roller cleaning paper (KV-SS03), please contact your dealer, or call our Supplies and Accessories department at 1-800-726-2797 (U.S.A. only).

KEEP AWAY FROM FIRE.

Others

- Make sure to remove paper clips and staples from documents before scanning. Failing to do so can damage the unit, document, or both.
- Do not use thinner, benzine, or cleaners containing abrasives or surfactants, for cleaning the outside of scanner.
- In usage scenarios that require accuracy or reproducibility in scanned images, there may be cases where the desired image cannot be obtained, such as half-tone images or markings from fluorescent pens.

2.2 Security Notice

Panasonic cannot be responsible for following types of damages.

- Any damages due to misuse of this unit.
- Any damages due to security or other network-related problems. (When this unit is connected to a network, it is the responsibility of the user to connect it to a network that implements appropriate security measures.)
- Any damages due to leakage of your information.

2.2.1 Management of documents and scanned data

The management of documents and scanned data is the responsibility of the user.

- Make sure you have the same number of pages for important documents both before and after scanning, and take care not to leave any pages in the scanner. Before discarding scanned documents, it's recommended to inspect scanned images to ensure all documents are captured properly.
- Periodically back up important data.
- When having your computer or hard disk serviced, or when disposing of your computer or hard disk, completely erase any stored image data.



2.2.2 Management of setting information

The management of setting information, such as network configurations, passwords, e-mail addresses, etc., is the responsibility of the user.

- Keep a copy of all important data. If you have the unit serviced, etc., data stored in this unit may be changed or erased.
- Set a user name and password before using Configuration Web (page 66).
 - Do not use a password that can easily be guessed.
 - The password should be unique. Do not use the same password for other purposes.
 - Keep the password secret.
 - Change the password periodically.
- Please contact your dealer when the unit needs to be serviced.
- Erase all of the settings in the unit before you discard or transfer the unit. Refer to "11.7 Factory Reset" (page 110) to erase the settings.

2.3 Check the Accessories

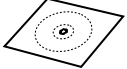
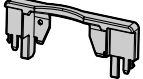
Check that all accessories are included before installing the unit. In the event that an item is missing, please contact your dealer.

Accessory	Name	Notes
	USB cable	—
	Software / Manual CD-ROM	Drivers, Applications, Utilities, Documents
	Mixed batch card guide	When the unit is shipped, this is stored in the feed tray. For details, see "6.3.3 Mixed Batch Card Guide (ADF)" (page 47).
	Quick Installation Guide	—
	Power cord	Use the power cord appropriate for where you use the unit.

Note

- It is highly recommended to keep the original carton and all packing materials. They are necessary when repacking.
- [For United States only]
Applicable limited warranty information is included on the Software / Manual CD-ROM.

2.3.1 Optional Accessories

Part Name	Part Number	Notes
Roller exchange kit <ul style="list-style-type: none"> • Paper feed roller • Double feed prevention roller module 	KV-SS061	See "10.3 Replacing the Rollers" (page 94).
Roller cleaning paper	KV-SS03	See "Roller Cleaning Paper" (page 13).
Carrier sheet	KV-SS077	See "6.2.1.4 Carrier sheet (KV-SS077) " (page 36).
Image Capture Plus Add-in (1 license)	KV-SS092	Required to installing OCREngine for Image Capture Plus on 2 or more PCs. (For 1 license)
Image Capture Plus Add-in (10 license)	KV-SS093	Required to installing OCREngine for Image Capture Plus on 2 or more PCs. (For 10 license)
Image Capture Plus (OCR module for network scan) [10-user license]	KV-SS094	See "7 Scan Server" (page 64).
Image Capture Plus Zonal OCR Add-in (1 license)	KV-SS095	Extend the maximum number of fields for zone OCR in Image Capture Plus from 3 to 10. (For 1 license)
Image Capture Plus Zonal OCR Add-in (10 license)	KV-SS096	Extend the maximum number of fields for zone OCR in Image Capture Plus from 3 to 10. (For 10 licenses)

Note

- To purchase optional accessories, contact your dealer.

3 Location of Controls

3.1 Main Unit

3.1.1 Front

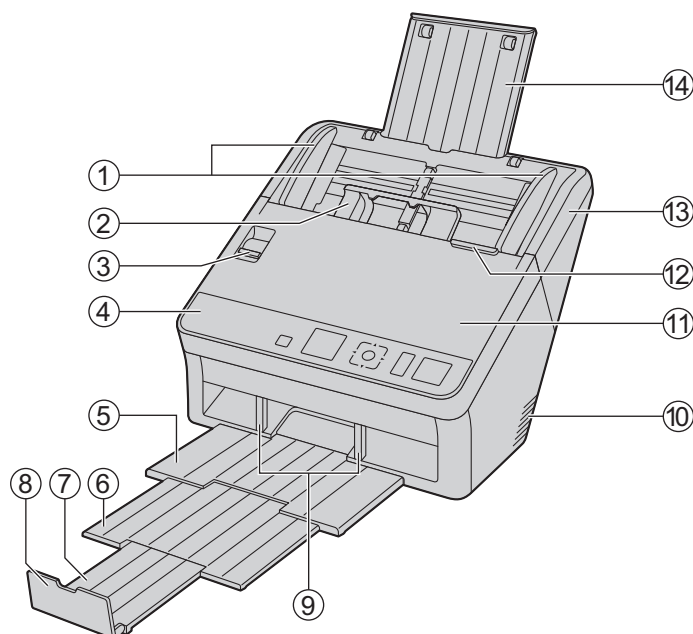

① **Document guides**

② **Mixed batch card guide**

When the unit is shipped, this is stored in the feed tray. For details, see "6.3.3 Mixed Batch Card Guide (ADF)" (page 47).

③ **Manual feed selector**

You can select the document feeding method.

☐ : Manual feeding

☑ : Automatic feeding

④ **Operation panel**

For details, refer to "5 Operation Panel" (page 25).

⑤ **Exit tray**

⑥ **Exit extension tray 1**

⑦ **Exit extension tray 2**

⑧ **Exit stopper**

⑨ **Exit guides**

⑩ **Fan exhaust vent**

⑪ **ADF door**

3.1.2 Rear

⑫ **ADF door release**

 Push to open the ADF door.

⑬ **Feed tray**

 Load the documents with the surface to be scanned facing down.

 Make sure to remove paper clips and staples from documents.

⑭ **Feed extension tray**

3.1.2 Rear

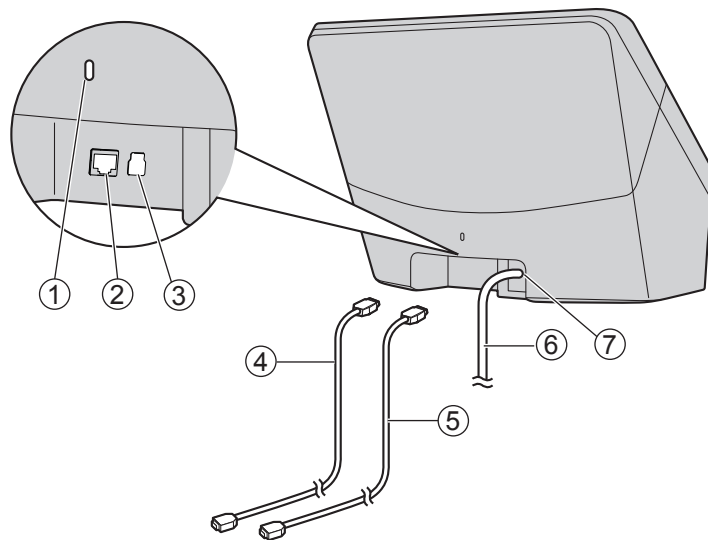

① **Security slot**

Use a commercially available security cable.

② **LAN connector**

③ **USB connector**

④ **LAN cable (not supplied)**

To assure continued emission limit compliance, use only shielded LAN cable. The cable should be a CAT 5 (Category 5) or higher for 10Base-T / 100Base-TX, or CAT 5e (Enhanced Category 5) or higher for 1000Base-T.

⑤ **USB cable**

Connect the USB cable to the scanner and the other end of the USB cable to the computer.

⑥ **Power cord**

⑦ **AC inlet**

4 Installation

4.1 Required Space Around the Scanner

In order to ensure proper operation, install the unit maintaining the proper distances from surrounding objects, as shown in the following illustration.

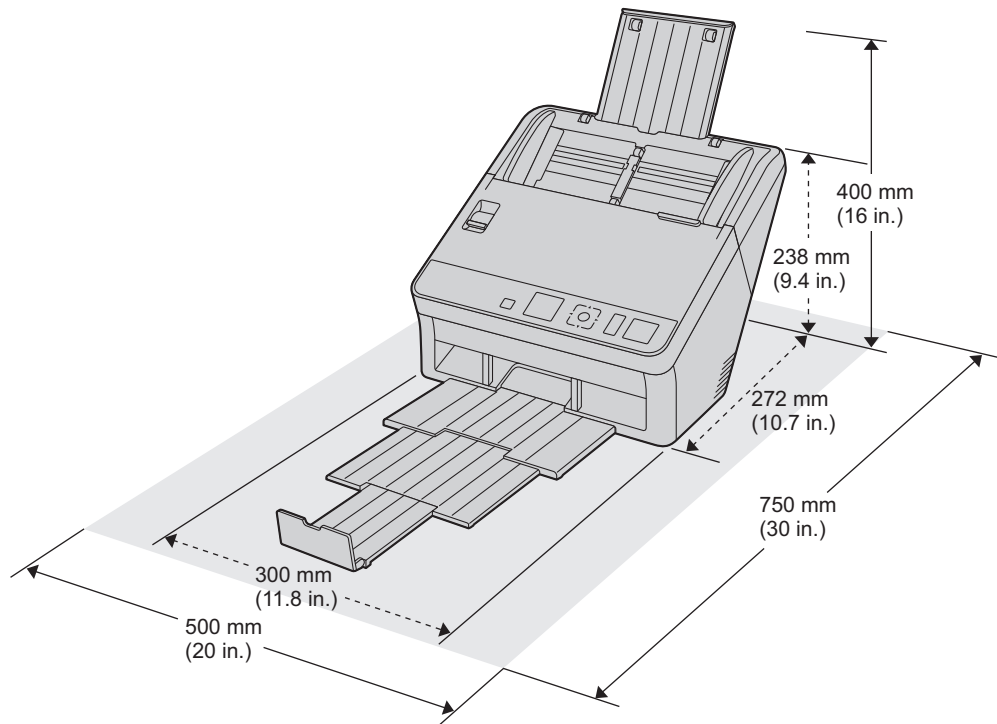

4.2 Moving the Unit

When moving the unit, hold the part as shown in the following illustration.

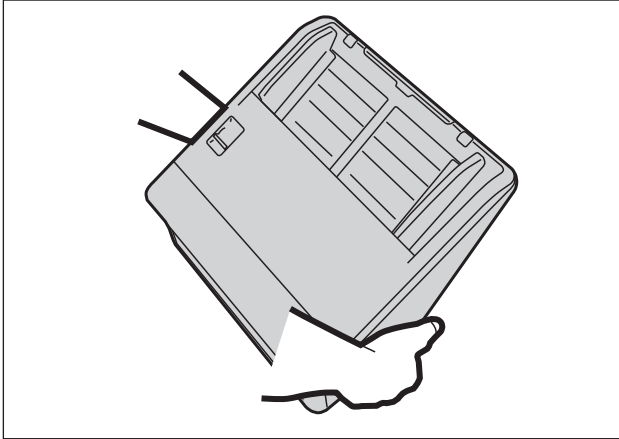

Notice

- Do not hold the feed tray when moving the unit.

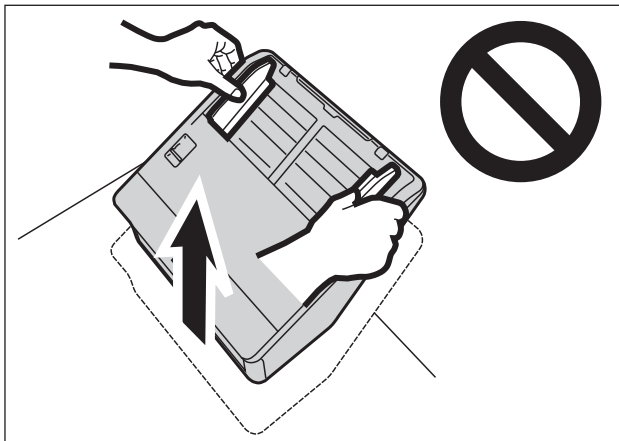

- Do not move the unit immediately from a cold place to a warm place. It may cause condensation, which may damage the unit. Using the unit immediately will cause the document scanning to be imperfect. To avoid this, clean the inside rollers with a dry and soft cloth, leave the unit in a warm place for 1 or 2 hours, and then use the unit after you make sure that the inside of the unit has dried.
- Do not place the unit in extremely high temperatures such as near heat sources, etc.

4.3 Installing the Software

- When turning on the unit's power for the first time, select the language used on the LCD by using the ▲ or ▼ cursor buttons, and then press the OK button to complete your selection.
- You can change the language used on the LCD. For details, see "6.1.3 Changing the language used on the LCD" (page 31).
- When turning on the unit's power for the first time, set the date and time by using the ▲, ▼, ◀ or ▶ cursor buttons, and then press the OK button. For details, see "6.1.4 Changing the date and time" (page 31).

Notice

- Make sure to log on as an administrator to install the software.
- Use only the power cord and the USB cable that are provided with the unit.

The software on the enclosed Software / Manual CD-ROM can be installed on your computer. You can select from the 2 installation methods below, depending on your needs.

a. Complete: Install all the drivers, applications, utilities and Operating Manual.

b. Custom: Install only selected items.

Note

- Normally, it is recommended to select [Complete].

4.3.1 When using this unit with a USB connection

Note

- Make sure to connect the unit to your computer after installing the software. Connecting the unit to your computer and turning on the unit's power before installing the software may influence the software installation. If you connect the unit to your computer and turn on the unit's power before installing the software, install the software after disconnecting the unit from your computer.
1. Check that the unit has been turned OFF.
 - If the power is on, turn off the unit's power (page 31).
 2. Insert the Software / Manual CD-ROM into the CD/DVD drive on your computer.
 - The setup window will appear.
 - If the AutoPlay dialog box is displayed, select [CDRun.exe].
 - If the setup window does not appear, double-click [CDRun.exe] in the Software / Manual CD-ROM.
 3. Check the [Read me first] file.
 4. Select the desired installation methods from "Software" on the left side of the screen.
 - If you selected [Custom], select the item that you want to install. If you select TWAIN or ISIS, Image Capture Plus will also be installed.
 5. Follow the instructions on the screen and complete the installation.
 - Select [USB] as the connection method for the scanner.
 - Restart your computer if you are prompted to do so.
 6. Plug in the power cord and connect the USB cable.
 7. Turn ON the unit's power (page 31).

4.3.2 When using this unit with a wired LAN connection

For details about network-related settings, consult your network administrator.

1. Insert the Software / Manual CD-ROM into the CD/DVD drive on your computer.
 - The setup window will appear.
 - If the AutoPlay dialog box is displayed, select [CDRun.exe].
 - If the setup window does not appear, double-click [CDRun.exe] in the Software / Manual CD-ROM.
2. Check the [Read me first] file.
3. Select the desired installation methods from "Software" on the left side of the screen.
 - If you selected [Custom], select the item that you want to install. If you select TWAIN or ISIS, Image Capture Plus will also be installed.
4. Follow the instructions on the screen and complete the installation.
 - Select [Wired LAN] as the connection method for the scanner.
 - Restart your computer if you are prompted to do so.
 - If multiple scanners are displayed, select the scanner with the same host name as the unit. You can confirm the host name of the unit as follows.
 - Press and hold the Skip/Menu button (**▶|**) for 1 second or more. → [Network Setting] → [Host Name]

When using a DHCP server:

Select [Automatic Configuration (DHCP)] for the IP address.

If the unit cannot connect to the network, confirm whether the DHCP server is running correctly.

When not using a DHCP server:

Select [Manual Configuration (Static IP)] for the IP address.

Connect the unit to your computer via USB, following the instruction on the screen. Then, configure the network settings (page 103).

Notice

- After the installation is complete, check that the network-related functions are configured correctly.
- If you are not using this scanner with a USB connection, remove the USB cable.

4.4 Viewing Operating Manual and Help Installed

You can view the Operating Manual and the software help installed on the computer.

4.4.1 To view the Operating Manual

1. Select [All Programs] → [Panasonic] → [Scanner Manuals].
2. Select the manual.
 - The manual will open.

Note

- In Windows 8 and Windows 10, select the [Panasonic Document Scanner] section on the Apps screen.

4.4.2 To view the help

For Image Capture Plus

1. Select [All Programs] → [Panasonic] → [Image Capture Plus] → [Image Capture Plus Help].

For User Utility or Scan Button Setting Tool

1. Select [All Programs] → [Panasonic] → [Scanner Tools].
2. Select that item's help.

Note

- In Windows 8 and Windows 10, select the [Panasonic Document Scanner] section on the Apps screen.

For Network Setting Tool, Network Scanner Select Tool or Scan Server Setting Tool

1. Start the program.
2. Click the help button.

For TWAIN or ISIS

1. Click the help button on the screen of each driver.

5 Operation Panel

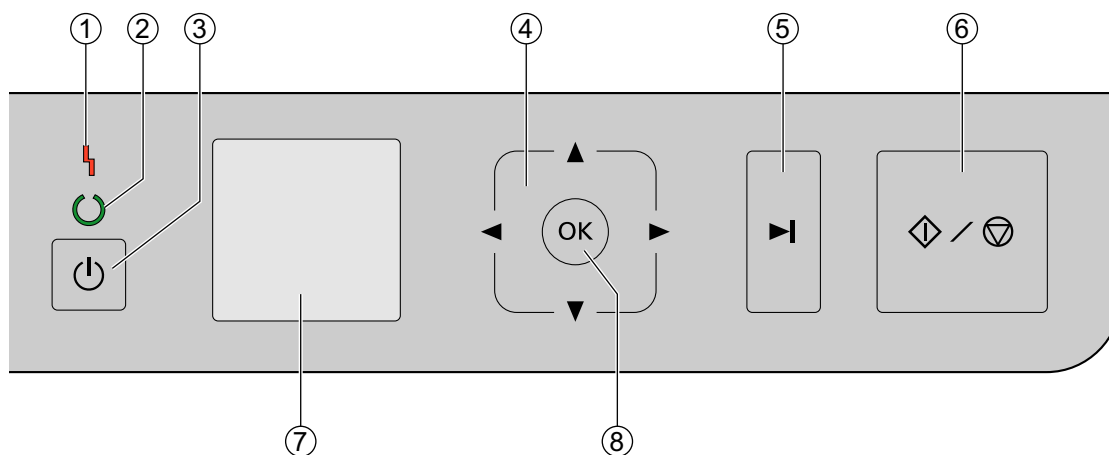

- ① **LED (Red)**
Lights when an error occurs.
- ② **LED (Green)**
Shows the scanner's status.
- ③ **Power button (⏻)**
For details, see "6.1.1 Turning ON/OFF the unit's power" (page 31).
- ④ **Cursor button**
- ⑤ **Skip/Menu button (▶|)**
 - If you press this button after a double feed is detected and scanning has been paused, the document (or documents) detected as a double feed will be scanned. Scanning will continue after the document is scanned.
 - If you press this button in ready mode, you will change the push scan mode. For details, see "6.4 Using Push Scan" (page 54).
 - If you press and hold this button for 1 second or more in ready mode, the menu screen will be displayed on the LCD. For details, see "5.3 Menu screen" (page 28).
 - If you press this button when the Menu screen is displayed, you will return to the previous screen.
- ⑥ **Start/Stop button (◀/⏻)**
 - If you set [Wait Key] for "Manual Feed Mode" in your application software, pushing this button starts scanning. For details about "Manual Feed Mode", refer to the Image Capture Plus, TWAIN, or ISIS help.
 - During scanning, pushing this button stops scanning.
 - If you press this button after a double feed is detected and scanning has been paused in pull scan, scanning will stop without being scanned.
 - If you press this button when the Menu screen is displayed, you will return to the home screen.
- ⑦ **LCD**
Selected jobs, error codes, notification messages, and the scanner status are displayed.
- ⑧ **OK button**

5.1 About LED

The status of the scanner is displayed by the LED (Red) (①) and the LED (Green) (②), as shown in the table below:

① LED (Red)	② LED (Green)	Status
OFF	OFF	Power OFF ^{*1}
OFF	ON	Ready mode or Scanning
OFF	Blinking (Fast)	Warming up
OFF	Blinking (Fast, 2 times consecutively)	Double Feed Skip mode
OFF	Blinking (Fast, 3 times consecutively)	Dog-ear detection skip mode
OFF	Blinking (Slow)	Sleep mode ^{*2} or Cleaning mode
Blinking (Slow)	ON	Notification mode ^{*3}
Blinking (Slow)	OFF	Network Error ^{*4}
ON	OFF	Error ^{*5}

*1 If the power off feature in sleep mode is enabled, and if no operation is performed for a certain period of time, the scanner will turn off automatically. Press the power button (⏻) of the scanner to turn it on. You can enable/disable the power off feature, and change the time until the scanner turns off. See "5.3 Menu screen" (page 28).

*2 If no operation is performed for 15 minutes or longer, the scanner will enter sleep mode automatically to conserve energy. Press any button (except the power button) on the scanner's operation panel to return to ready mode. The time until the scanner enters sleep mode can be changed. See "5.3 Menu screen" (page 28).











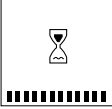

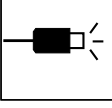
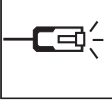
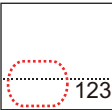





*3 For details about the notification, check the LCD or User Utility.

*4 For details about the network error, refer to "11.9 Error Codes and Error Messages" (page 115).

*5 For details about the error, refer to "11.9 Error Codes and Error Messages" (page 115).

5.2 About LCD



The status of the unit is displayed on the LCD as follows.

LCD	Status												
	The scanner is warming up.												
	The USB cable and LAN cable are not connected.												
	The USB cable is not connected when in USB mode.												
	The LAN cable is not connected when in Network PC mode.												
	<p>The Scanner status and scanning counter are displayed.</p> <ul style="list-style-type: none">  The following icons are displayed. <table border="1" data-bbox="443 1111 1465 1874"> <thead> <tr> <th data-bbox="443 1111 651 1160">icon</th> <th data-bbox="651 1111 1465 1160">Contents</th> </tr> </thead> <tbody> <tr> <td data-bbox="443 1160 651 1305">  </td> <td data-bbox="651 1160 1465 1305">The system counter is displayed.</td> </tr> <tr> <td data-bbox="443 1305 651 1451">  </td> <td data-bbox="651 1305 1465 1451">The scan counter is displayed.</td> </tr> <tr> <td data-bbox="443 1451 651 1597">  </td> <td data-bbox="651 1451 1465 1597">Clean the rollers.</td> </tr> <tr> <td data-bbox="443 1597 651 1742">  </td> <td data-bbox="651 1597 1465 1742">Replace the rollers.</td> </tr> <tr> <td data-bbox="443 1742 651 1874">  </td> <td data-bbox="651 1742 1465 1874">Clean the Conveyor and Scanning Glasses.</td> </tr> </tbody> </table> 	icon	Contents		The system counter is displayed.		The scan counter is displayed.		Clean the rollers.		Replace the rollers.		Clean the Conveyor and Scanning Glasses.
icon	Contents												
	The system counter is displayed.												
	The scan counter is displayed.												
	Clean the rollers.												
	Replace the rollers.												
	Clean the Conveyor and Scanning Glasses.												

Examples of displays of scanner statuses are as follows.

G: nn GROUP NAME	Group number (two-digit) and Group name of job. Push Scan Mode: USB mode
J: nn JOB NAME	Job number (two-digit) and Job name. Push Scan Mode: USB Mode / Network PC mode
PC: nn PC NAME	PC number (two-digit) and PC name. Push Scan Mode: Network PC mode
★: n PRESET GROUP NAME	Preset group number (one-digit) and preset group name. Push Scan Mode: Preset Scan mode
PS: nn PRESET NAME	Preset number (two-digit) and preset name. Push Scan Mode: Preset Scan mode
Unn MESSAGE	Error code and Error message. • For details, refer to "11.9 Error Codes and Error Messages" (page 115).

5.3 Menu screen

The Menu screen is displayed when you press and hold the Skip/Menu button () for 1 second or more. Select [Function Setting], [Counter], [Network Setting] or [Maintenance] using  or  of the cursor button. Press the OK button to complete your selection.







If you press the Skip/Menu button () when the Menu screen is displayed, you will return to the previous screen.

If you press the Start/Stop button () when the Menu screen is displayed, you will return to the home screen.

Note

- Some settings can also be configured using Configuration Web. For details, refer to "8 Using Configuration Web" (page 66).

Function Setting

Configures each function's setting. Use  or  of the cursor button to select items, and , ,  or  to change their value. Press the OK button to complete your selection.

Setting contents

Item	Contents
Version	Display the scanner's firmware version.
USB ID	Display the scanner's USB serial number.
Date & Time	Set the date and time.
Language	Set the language used on the LCD.
Sleep (min.)	Set the length of time before entering sleep mode (1 to 120 min.).
Auto Off	Enables(On) or disable (Off) the power auto-off function.
Auto Off (hour)	Set the length of time before the auto-off function activates (15 min. to 72 hrs.).
Auto Off (min.)	

Item	Contents
LCD Contrast	Set the LCD contrast (5 levels).
Roller Cleaning Notification	Enable (On) or disable (Off) the roller cleaning notification.
Roller Replacement Notification	Enable (On) or disable (Off) the roller replacement notification.
Glass Cleaning Notification	Enable (On) or disable (Off) the scanner's internal cleaning notification function.
Select Counter	Select the counter from [Scan] or [System] that appears on the Home screen and the screen displayed during scanning.
Home Screen	Select whether to display [USB Job] or [Preset] on the Home screen.

Counter

Select the counter using ▲ or ▼ of the cursor button, and press the OK button to complete your selection. The types of selectable counters are shown below.

Setting contents

Item	Contents
Scan Counter	The number of documents scanned during the scanning process. The scanned quantity is cleared each time you start scanning.
System Counter	The number of documents scanned by the scanner since it was shipped from the factory.
After Clean Roller Counter	The number of documents scanned since clearing the counter after cleaning the rollers. Clear after cleaning the rollers.
After Replace Roller Counter	The number of documents scanned since clearing the counter after replacing the rollers. Clear after replacing the rollers.
Clear Clean Roller Counter	Set the After Clean Roller Counter to zero (0).
Clear Replace Roller Counter	Set the After Replace Roller Counter to zero (0).
Clean Roller Timing	Displays the number of documents that can be scanned until the roller cleaning notification appears.
Replace Roller Timing	Displays the number of documents that can be scanned until the roller replacement notification appears.

Network Setting

Setting contents

Item	Contents
Network Status	Display the network status.
DHCP	Enable (On) or disable (Off) DHCP.

5.3 Menu screen

Item	Contents
AutoIP	Enable (On) or disable (Off) Auto IP. If DHCP is disabled, this setting cannot be changed. This setting can also be changed from Network Setting Tool (page 103).
IP Address	Set the IP address. If DHCP is enabled, this will be set automatically and cannot be changed. This setting can also be changed from Network Setting Tool (page 103).
Subnet Mask	Set the subnet mask. If DHCP is enabled, this will be set automatically and cannot be changed. This setting can also be changed from Network Setting Tool (page 103).
Default Gateway	Set the default gateway. If DHCP is enabled, this will be set automatically and cannot be changed. This setting can also be changed from Network Setting Tool (page 103).
DNS Server 1	Set the primary DNS server.
DNS Server 2	Set the secondary DNS server.
WINS Server 1	Set the primary WINS server.
WINS Server 2	Set the secondary WINS server.
HTTPd	Enable (On) or disable (Off) the HTTPd. If HTTPd is disabled, "Configuration Web" is not available.
Host Name ^{*1}	Set the host name for the scanner (up to 15 characters).
MAC Address	Display the scanner's MAC Address.

*1 For details, refer to "8.2.1 Available characters in Configuration Web" (page 68).

Maintenance

Setting contents

Item	Contents
Cleaning Mode	Start Cleaning Mode. For details, see "10.2.4 Cleaning Mode" (page 91).

6 Operation

6.1 Basic Operations

6.1.1 Turning ON/OFF the unit's power

Turning ON the unit's power

1. Press the power button (⏻).
 - The LED (Green) will flash and then turn on.

Turning OFF the unit's power

1. Press and hold the power button (⏻) for 1 second or more to turn the unit off.

6.1.2 Returning from sleep mode

1. Press any button other than the power button (⏻) on the operation panel.

6.1.3 Changing the language used on the LCD

You can change the language used on the LCD.

1. Press and hold the Skip/Menu button (▶|) for 1 second or more.
2. Press the OK button.
3. Press ▼ of the cursor button 3 times.
4. Press the OK button.
5. Use ▲ or ▼ of the cursor button to select a language used on the LCD.
6. Press the OK button.

6.1.4 Changing the date and time

You can change the date and time set in the unit.

1. Press and hold the Skip/Menu button (▶|) for 1 second or more.
2. Press the OK button.
3. Use ▲ or ▼ of the cursor button to select "Date & Time".
4. Press the OK button.
5. Use ▲, ▼, ◀ or ▶ of the cursor button to change the value.
6. Press the OK button.

6.1.5 Opening/Closing the ADF door

Opening the ADF door

1. Press the ADF door release (①), and open the ADF door (②).

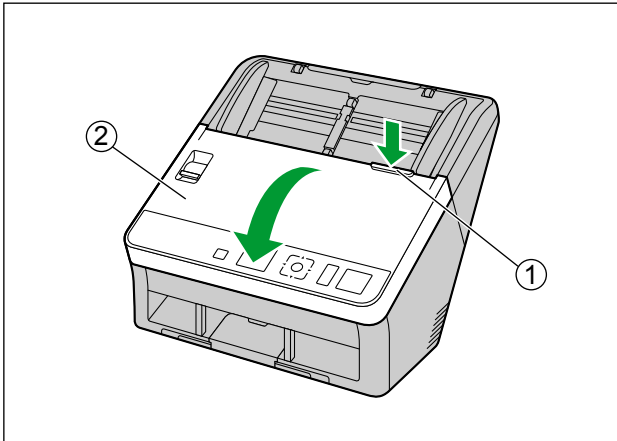

Closing the ADF door

1. Push both sides of the ADF door down slowly until it clicks into place.

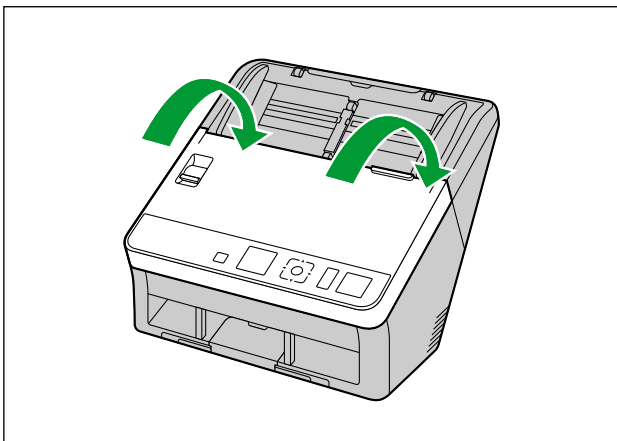

6.2 Preparing Documents for the ADF

6.2.1 About documents for the ADF

Notice

- Make sure to remove paper clips and staples from documents before scanning. Failing to do so can damage the unit, document, or both.

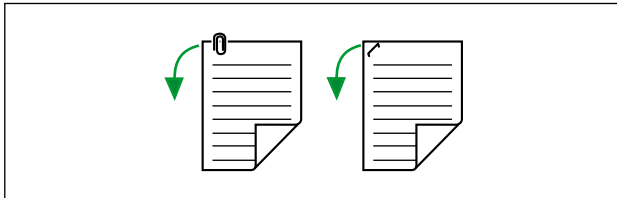

- Before feeding, ensure that the document is not creased or folded. If the document is creased or folded, a paper jam or damage to the document may occur.

6.2.1.1 Compatible Paper

Paper size:

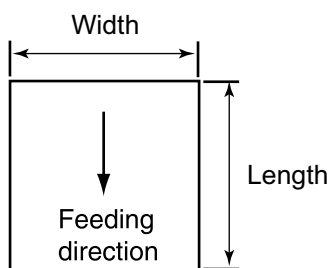

The compatible paper sizes for this unit are as follows.

Width	48 mm – 216 mm (1.9 in. – 8.5 in.)
Length	When feeding one sheet: 54 mm – unlimited (2.1 in. – unlimited) ^{*1} When feeding multiple sheets: 54 mm – 356 mm (2.1 in. – 14 in.)

^{*1} Using "Long Paper", you can scan long documents by splitting them into smaller parts. For details about "Long Paper", refer to the Image Capture Plus, TWAIN, or ISIS help.

Paper thickness:

0.04 mm – 0.5 mm (1.6 mils – 19.7 mils)

Note

1 mil = 0.001 in.

Paper weight:

20 g/m² – 413 g/m² (5 lb. – 110 lb.)

Paper capacity for the feed tray:

100 sheets (80 g/m² (21 lb.), High-quality woodfree paper)^{*1}

^{*1} Less than 100 mm (3.9 in.) length paper or legal size: 75 sheets (80 g/m² (21 lb.), High-quality woodfree paper)

Recommended paper types:

<ul style="list-style-type: none"> • High-quality woodfree paper • Bond paper • Newspaper 	<ul style="list-style-type: none"> • Recycled paper • OCR paper • Bank checks
----------------------------------------------------------------------------------------------------------------------------	----------------------------------------------------------------------------------------------------------------

Note

- High-quality woodfree paper is the recommended paper type.

Curl and Folding:

Documents must also meet the following conditions:

Curl	
Folding	

Mixed documents

Documents must also meet the following conditions:

Width	Same width
Length^{*1}	The length of the longest sheet is at most 2 times that of the shortest sheet.
Thickness	The thickness of the thickest sheet is at most 1.5 times that of the thinnest sheet.

*1 Using "Length Control", you can adjust the length of scanned image automatically. For details about "Length Control", refer to the Image Capture Plus, TWAIN, or ISIS help.

6.2.1.2 Compatible Card

The compatible card types for this unit are as follows.

ISO format card:

Size:	85.6 mm × 54 mm (3.4 in. × 2.1 in.)
Thickness:	0.76 mm (0.03 in.) Embossed card up to 1.4 mm (0.055 in.)

- Use the mixed batch card guide (page 47) when scanning mixed media (cards and papers) at the same time.
- Embossed cards are also compatible. When scanning embossed cards, it is recommended to place them in landscape orientation with the side to be scanned facing up.
- A maximum of 3 cards can be loaded on the feed tray. When loading, ensure that the embossed portions of cards do not stick together.
- Use the landscape orientation when scanning an embossed card. If the scanning fails, place the card upside down, and then try again.

6.2.1.3 Compatible Passport

Use the carrier sheet (KV-SS077) to scan passport (page 36).
The compatible passport types for this unit are as follows.

Passport size:

Width:	130 mm (5.1 in.) or less
Length:	188 mm (7.4 in.) or less
Thickness:	4 mm (0.15 in.) or less (including carrier sheet)

6.2.1.4 Carrier sheet (KV-SS077)

You can use an optional carrier sheet (KV-SS077) to scan passport. When using the carrier sheet, please note the following conditions for the documents. For details about compatible passport, refer to "6.2.1.3 Compatible Passport" (page 35).

How to insert the passport into the carrier sheet

Insert the passport so that the thinner part (photo page) is at the bottom of the carrier sheet, as shown in the illustration.

Make sure the documents do not protrude from the carrier sheet.

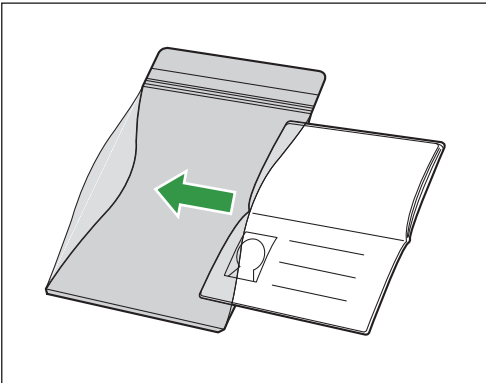

Note

- When using a carrier sheet, please refer to "6.2.2.1 When using the carrier sheet" (page 44).
- Depending on the condition (operating environment, dirt, scratches, etc.) of the carrier sheet or passport, the image processing function may not work properly. Scan beforehand to confirm the scanned image.
- If the rollers are dirty, the scanned image will be stretched or distorted. In such cases, clean the rollers.
- If vertical streaks appear on the scanned image, clean the scanning glasses and the carrier sheet. Vertical streaks may be caused by scratches on the carrier sheet. If vertical streaks appear after cleaning the scanning glasses and the carrier sheet, replace the carrier sheet, and then scan the passport.

6.2.1.5 Incompatible Documents

The following types of documents may not scan properly:

- Torn or frayed documents
- Curled, wrinkled or folded documents
- Carbon paper
- Perforated or punched paper
- Non-rectangular or irregularly shaped paper
- Coated paper
- Chemical paper such as carbonless copy paper
If papers like this are scanned, the rollers will need to be cleaned frequently and the lifetime of the rollers may be shortened.
- Paper with wood or metal content
- Photographs
Photographs may be scratched or damaged.
- Extremely smooth, shiny paper, or paper that is highly textured

Notice

- Paper with a glossy surface such as coated paper or photographs are susceptible to damage such as scratching.
- Scanning the following kinds of documents may contaminate the inside of the scanner or adversely influence the lifetime of the rollers. When scanning the following kinds of documents, clean the inside of the scanner frequently.
 - Documents with toner or graphite (pencil) powder
 - Documents treated chemically or containing impurities

Do not scan the following types of paper:

- Documents out of specified size, thickness, and weight
- Thermal or photosensitive paper
- Cloths or metallic sheets
- Transparent or partially transparent documents such as OHP sheet, tracing paper, plastic film, etc.
- Documents containing hard attachments such as metal or plastic (ex. clips or staples)
- Document with wet ink or cinnabar seal ink
- Damaged or notched documents or cards
- Glued documents

6.2.1.6 Notes about Documents for Scanning

- Depending on the paper type, scanning results may be poor when you scan incompatible documents, or even documents that should be compatible.

If scanned images are skewed, paper jams occur, or double feeding occurs, try scanning again after doing the following:

- Clean the inside of the scanner (page 83).
- Reduce the number of sheets of paper loaded on the feed tray.
- Change the orientation (portrait/landscape) of the placed documents.
- In the scan settings, set "Feeding Speed" to [Slow].^{*1}
- Scan the documents using manual feeding.

^{*1} For details about configuring the scan settings, refer to the Image Capture Plus, TWAIN, or ISIS help.

- When scanning important documents, confirm that the number of scanned images matches the number of pages in the feed tray. Also, check the condition of the scanned documents.

6.2.1.7 Notes about Double Feed Detection

This unit uses an ultrasonic sensor to detect double feeding (where two or more sheets of a document are fed at the same time).

- Double feeding cannot be detected with unsupported paper types.
- Even with supported types of cards, scanning them in portrait orientation may result in the detection of a double feed. In this case, try scanning them in landscape orientation, or disable the double feed detection.
- Documents must be 70 mm (2.8 in.) or longer for double feed detection to function.

6.2.2 Loading documents on the ADF

1. Pull out the feed extension tray in the direction of the arrow shown in the illustration below.

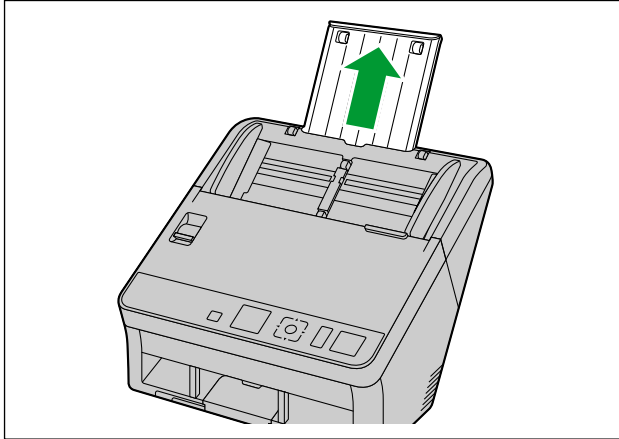

2. Adjust the document guides (①) slightly larger than the actual size of the documents.

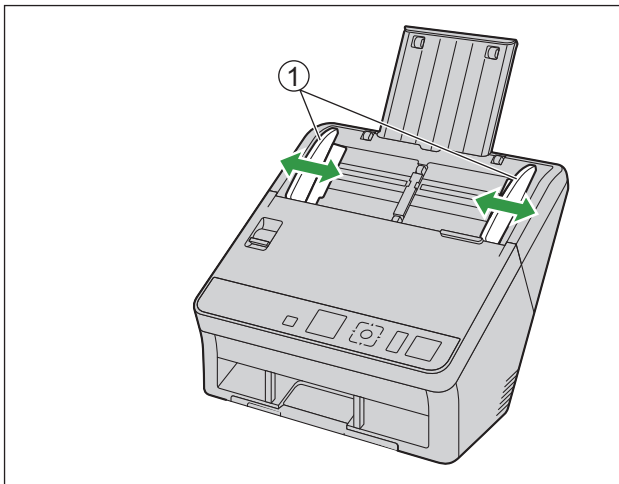

3. Raise the exit stopper.

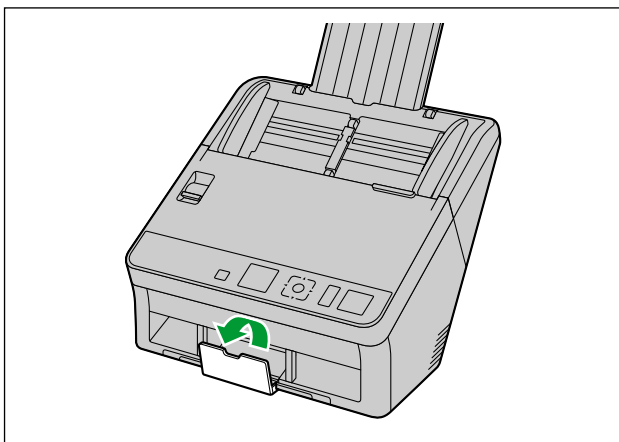

6.2.2 Loading documents on the ADF

4. Pull out the exit tray (①) and the exit extension trays (②, ③).

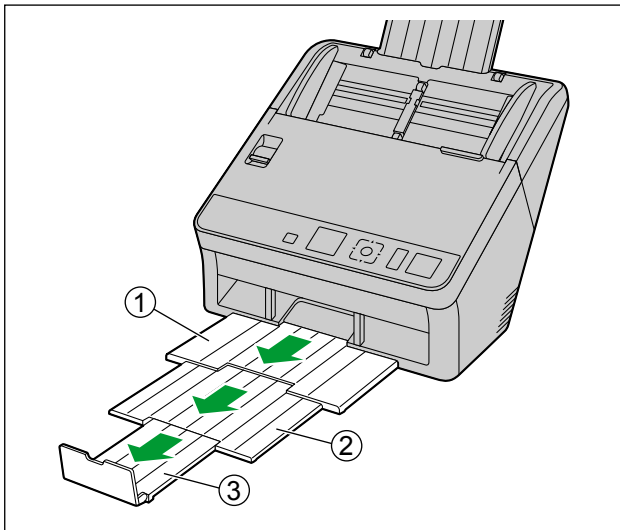

5. Fan the documents.

- Documents that have been stapled together or stacked together (as in a file folder) will need to be separated.

① Fan the stack of documents to separate all the edges.

② Hold both ends and bend the documents as shown in the illustration.

③ To flatten the documents, hold firmly and pull them apart as shown in the illustration.

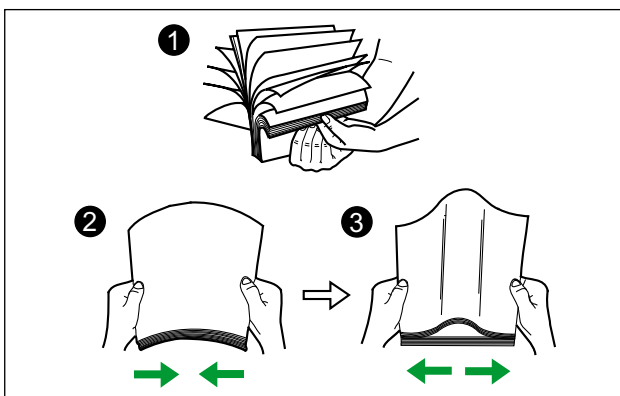

Repeat these steps as necessary.

6. Carefully align the documents.

- The documents feed better when the leading edges are aligned slantwise as shown in the illustration.

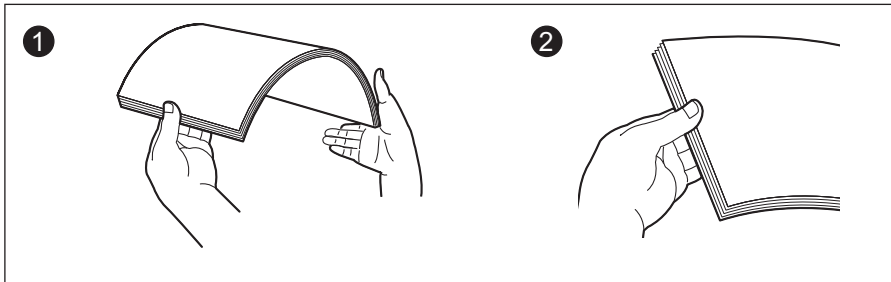

7. Place the documents on the feed tray with the side to be scanned facing down.

- Set the leading edge of documents as shown in the illustration (①).
- Insert the documents slowly until they stop.

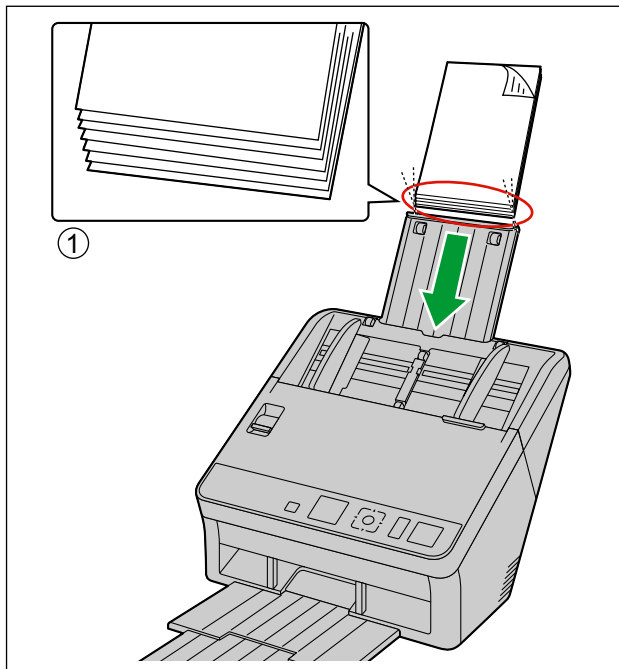

Note

- The height of the documents should not exceed the limit mark (MULTI-PAGE) on the document guide. Exceeding the limit mark may cause a paper jam or skewing.

6.2.2 Loading documents on the ADF

8. Adjust the document guides (①) to the size of the documents to be scanned.

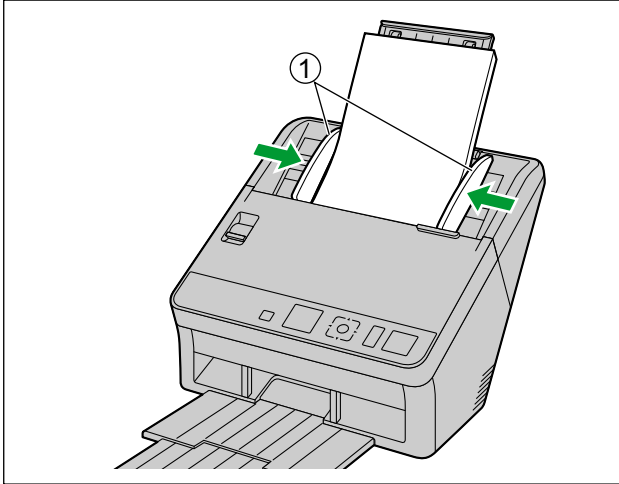

9. Hold the exit stopper (①) and adjust the exit extension trays (②, ③) to match the size of the scanned documents.

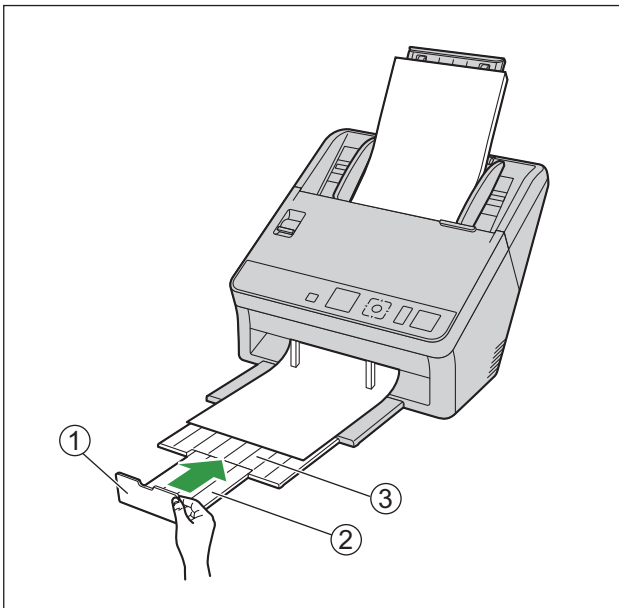

- When the documents are curled or a paper jam occurs, fold up the exit guides (①) and then resume scanning.

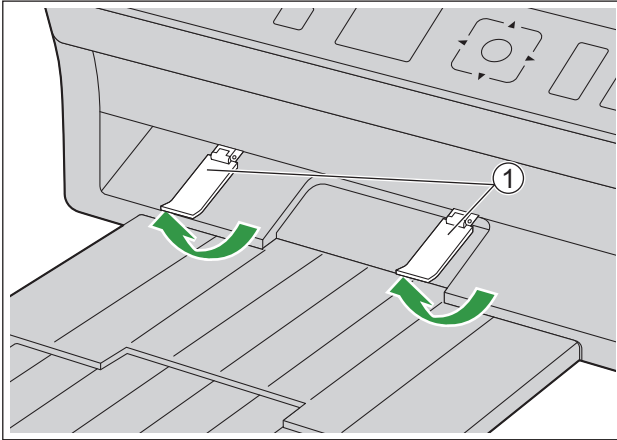

6.2.2.1 When using the carrier sheet

You can use an optional carrier sheet (KV-SS077) to scan passport. For details about the carrier sheet, refer to "6.2.1.4 Carrier sheet (KV-SS077)" (page 36).

1. Set the manual feed selector to manual feeding (page 46).

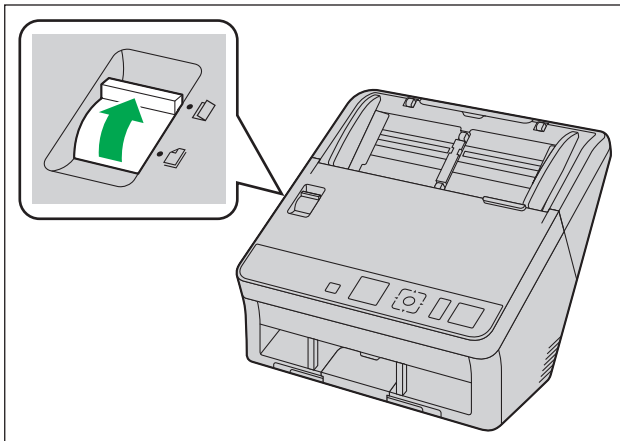

2. Place the carrier sheet (①) on the feed tray with the surface to be scanned facing down as shown in the illustration.

- Adjust the document guides (②) to the size of the carrier sheet to be scanned.

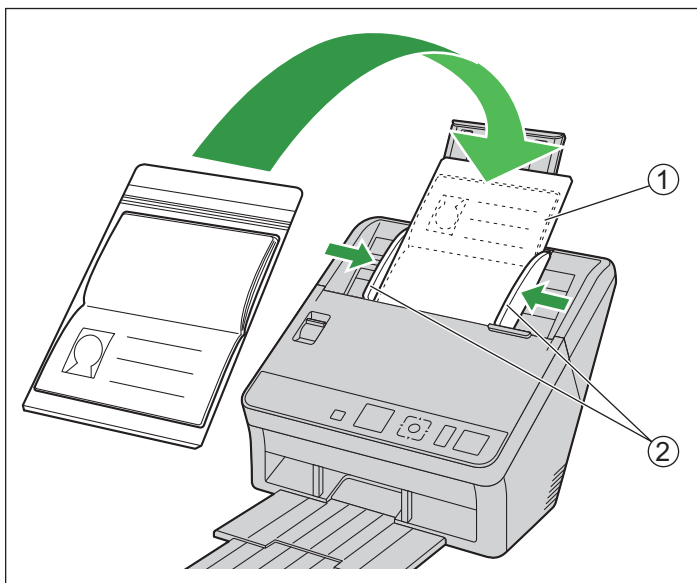

3. Insert the carrier sheet (①) until it stops as shown in the illustration.

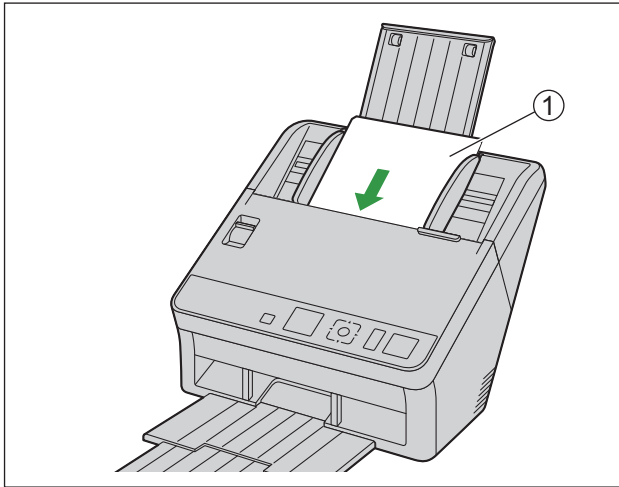

Note

- Make sure to insert the carrier sheet until it comes into contact with the paper feed roller.

6.3 Scanning Documents



1. Load the documents (page 39).
2. Open your scanning application and scan the documents.
 - For details about the application, refer to the help of each application.
 - You can also start up applications automatically to scan documents (push scan). For details about push scan settings, see "6.4 Using Push Scan" (page 54).
 - Remove documents after they have been scanned.

6.3.1 Switching the Background Color of Scanned Images

Using the software, you can switch the background color of scanned images between white and black. For details, refer to the Image Capture Plus, TWAIN, or ISIS help.

6.3.2 Using Manual feeding

You can select Manual feeding with the Manual Feed Selector.

-  : Manual feeding
-  : Automatic feeding

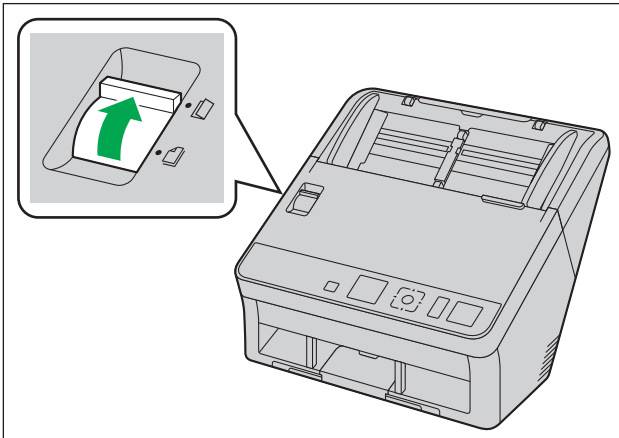

When using manual feeding, the documents are scanned without separation. Place the documents on the feed tray one by one.

Manual feeding is recommended to scan important documents or bound documents.

Automatic feeding is recommended for normal use.

Note

- Double feed detection is not available when using manual feeding.

6.3.3 Mixed Batch Card Guide (ADF)

No adjustment to the document guide is required when using the mixed batch card guide. The mixed batch card guide prevents a card from skewing when scanning paper documents and a card simultaneously.

6.3.3.1 Installing the mixed batch card guide

The mixed batch card guide is stored inside the feed tray. Install the mixed batch card guide as shown in the following illustration.

1. Remove the feed tray (①) from the unit.
 - Remove the left side of the feed tray (②) first as shown in the illustration.

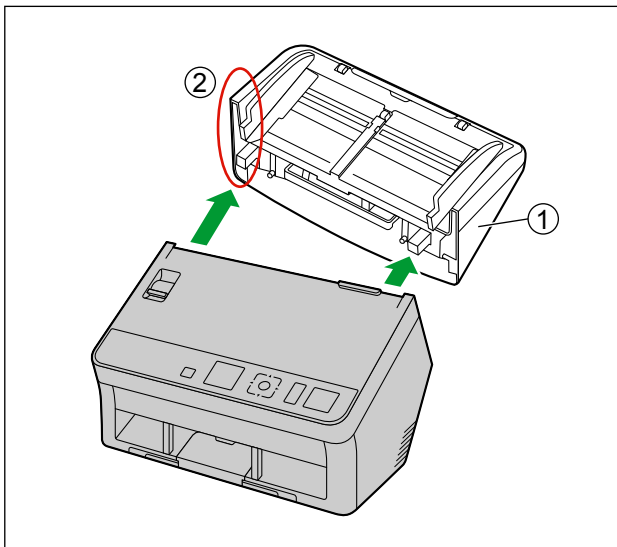

2. Pull out the mixed batch card guide (②) from the feed tray (①).

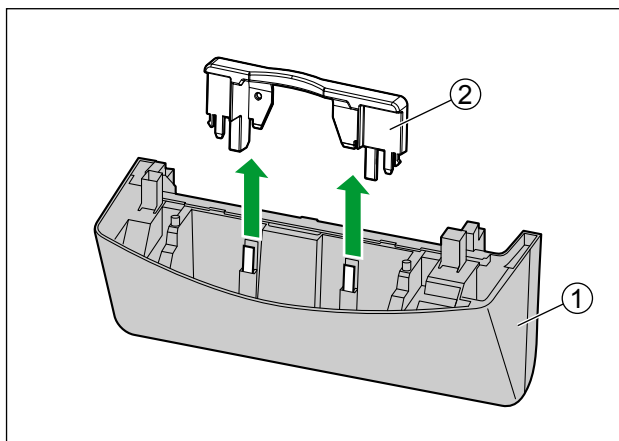

6.3.3 Mixed Batch Card Guide (ADF)

3. Attach the feed tray (①) to the unit.

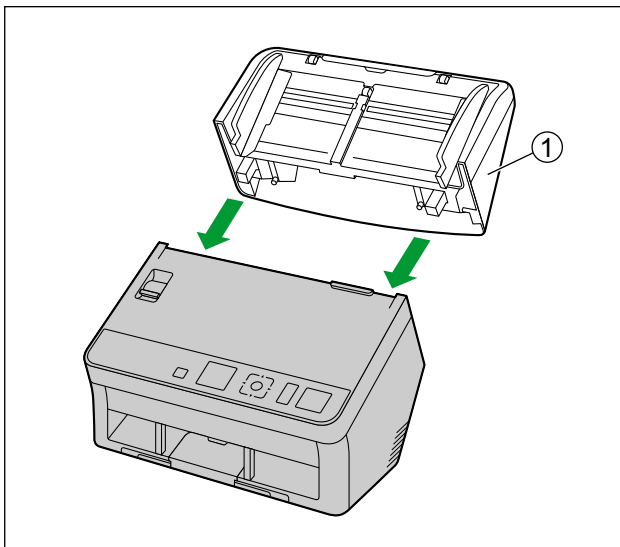

4. Attach the mixed batch card guide (①) to the unit.

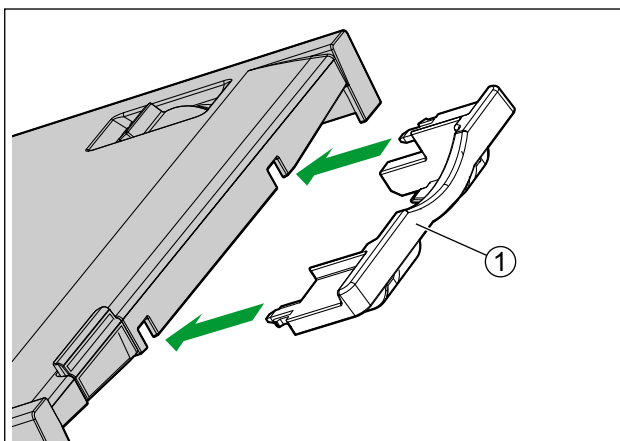

6.3.3.2 Removing the mixed batch card guide

Remove the mixed batch card guide as shown in the following illustration.

1. Remove the mixed batch card guide (①) from the unit.

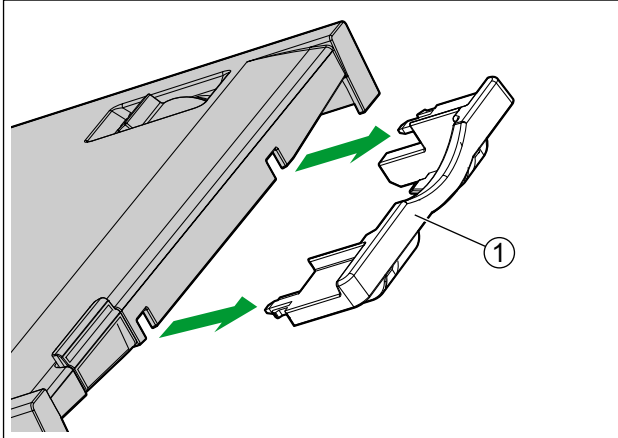

2. Remove the feed tray (①) from the unit.
 - Remove the left side of the feed tray (②) first as shown in the illustration.

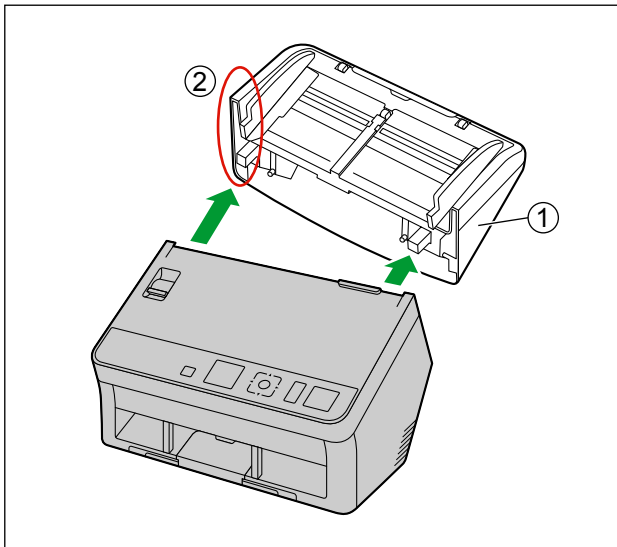

6.3.3 Mixed Batch Card Guide (ADF)

3. Attach the mixed batch card guide (②) to the feed tray (①).

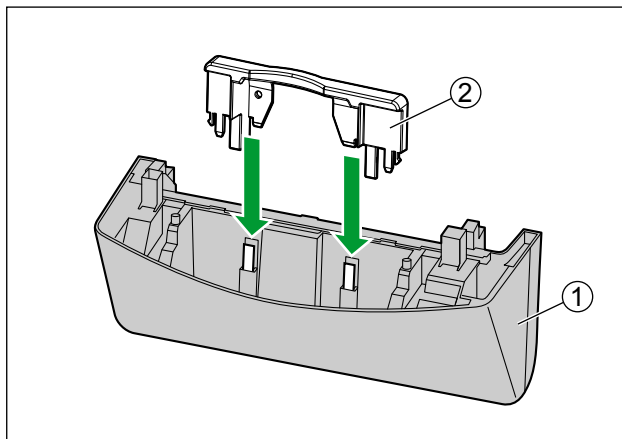

4. Attach the feed tray (①) to the unit.

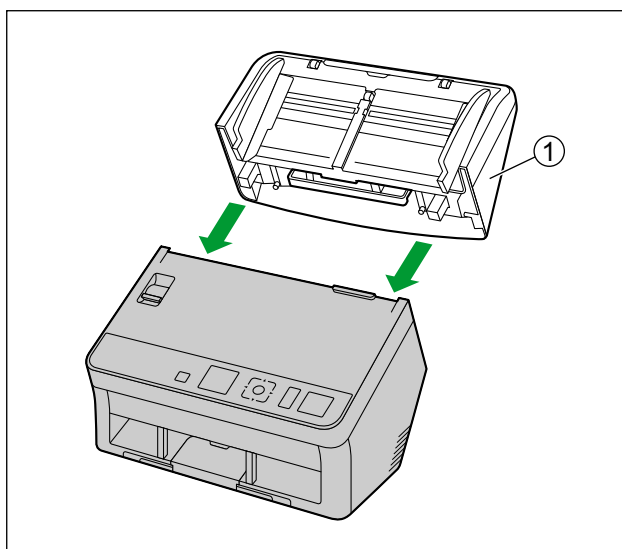

6.3.3.3 Using the Mixed Batch Card Guide

Set paper documents on the feed tray, and a card on the mixed batch card guide respectively.

- The card set on the mixed batch card guide is fed after completing the paper document scanning.
- For details about the compatible card types for this unit, refer to "6.2.1.2 Compatible Card" (page 35).
- Set the card in landscape orientation.
- Ensure that the embossed portions of cards do not stick together.
- A maximum of 3 cards can be set in the mixed batch card guide.
- If acceptable results cannot be obtained, try changing the scanning orientation or reversing the scan face of the card, and then perform scanning again.

Note

- When using the mixed batch card guide, the document guides cannot be adjusted to less than A5 size.
- Make sure that the total height of the paper on the feed tray does not exceed 2 mm (0.08 in.). (This is equivalent to about 20 sheets at 80 g/m² [21 lb.])

6.3.4 Using Control Sheets (ADF)

Placing a control sheet in the middle of documents lets you change the scanning conditions for pages scanned after the control sheet. Also, you can change the folder used to save the scan data of documents scanned after the control sheet.

- Print out control sheets from the included CD-ROM.

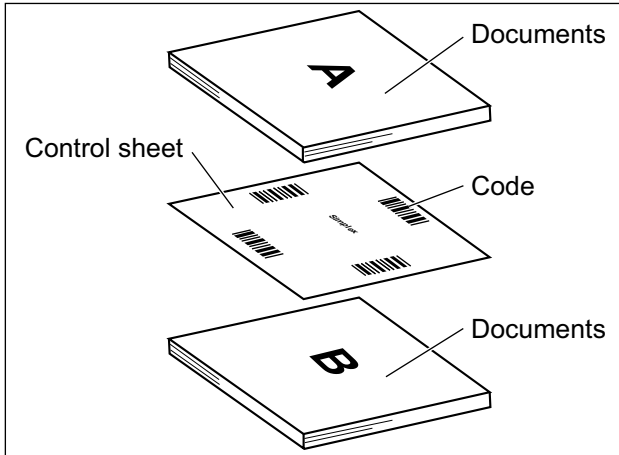

Control sheet functions

Simplex, Duplex, Binary, 256 level gray, Color, Dynamic Threshold, Dither, Error diffusion, Function #1 - #9, Separation Sheet

- For details about control sheets, refer to "Detect Control Sheet" in the Image Capture Plus, TWAIN, or ISIS help.
- For details about separation sheets, refer to "Detect Separation Sheet" in the Image Capture Plus, TWAIN, or ISIS help.

6.3.4.1 About Printing Control Sheets

- Print the control sheet at the specified size; do not enlarge or reduce the size.
- When printing the control sheet, make sure that the pattern is 25 mm (1 in.) from the top of the page and centered horizontally.

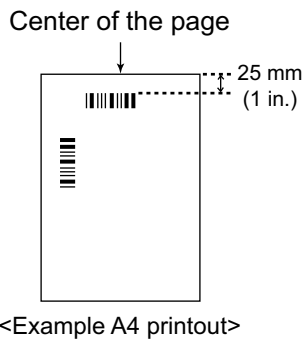

- Use the control sheet that is the same size as the document you are scanning.
- Be careful not to get the control sheet dirty.
- Do not fold or crease the control sheet.
- For details about control sheets, refer to "Detect Control Sheet" in the Image Capture Plus, TWAIN, or ISIS help.

Printing control sheets

Note

- In order to print control sheets, Adobe Reader must be installed on your computer.
 - Refer to the instruction manual for your printer for details about changing print settings.
1. Insert the included CD-ROM into the CD/DVD drive on your computer.
 - The setup window will appear.

Note

- If the AutoPlay dialog box is displayed, select [CDRun.exe].
 - If the setup window does not appear, double-click [CDRun.exe] in the Software / Manual CD-ROM.
2. Select [Control Sheet] from "Documents" on the right side of the screen.
 3. Print the control sheets at the same size as your document.

6.4 Using Push Scan

6.4.1 Outline of Push Scan

This unit has three modes for Push scan.

For details about the available functions for image processing, refer to "11.1 Available Functions When Scanning" (page 101).

USB mode

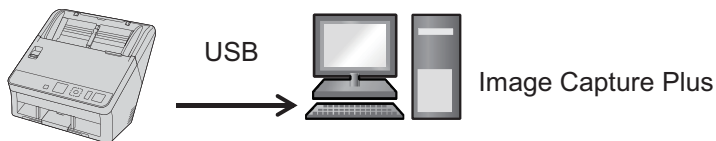

- This mode pushes the scanned data to a computer connected via USB.
- Both the scanner and Image Capture Plus process the image.
- Jobs and [Scan Button Settings] should be registered in Image Capture Plus in advance.
- When documents are placed on the feed tray (Touch Free Scanning), or when the OK button or the Start/ Stop button is pressed (Single Touch Scanning), Image Capture Plus will start automatically.

Network PC mode



- This mode pushes the scanned data to a computer connected via the LAN.
- Both the scanner and Image Capture Plus process the image.
- Jobs should be registered in Image Capture Plus in advance.
- When the Start/Stop button is pressed, Image Capture Plus will start automatically.

Preset Scan mode

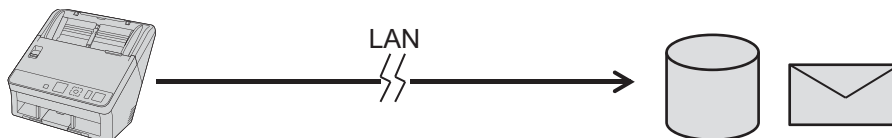

- This mode pushes the scanned data directly to an FTP server, a shared folder, or e-mail.
- Only the scanner processes the image.
- This mode is available when settings for Preset Scan have been configured in this unit using Configuration Web.

6.4.2 Output File

The output image file name is as follows.

Prefix	Item delimiter	Type Code	Item delimiter	Sequence ID ^{*1}	Dot	Extension
1 to 15 characters ^{*2}	1 character	1 character	1 character	5 characters	1 character	3 characters
Example Panasonic_ DOC01	-	M	-	00001	.	jpg

^{*1} If a Factory Reset is performed on the unit, the Sequence ID applied to file names pushed to all destinations will also be reset. Therefore, you should assign a different folder path from the existing one to prevent existing data from unexpectedly being overwritten.

^{*2} Up to 31 characters if [Location] is selected. Up to 78 characters if [Combination] is selected.

Prefix

Type of prefix	Number of characters	Contents
Host Name	3 to 15	Set the value of "Network Setting" in "IP Configuration" (page 74).
Date and Time	14	The format set in [Date & Time] (page 71). <ul style="list-style-type: none"> • YYYYMMDDhhmmss • MMDDYYYYhhmmss • DDMMYYYYhhmmss
User-defined Field	1 to 15	Set the value on "File Name" of "Scan Settings" (page 72).
Location	1 to 31	Set the value of "Network Setting" in "IP Configuration" (page 74).
Combination	1 to 78	The following contents can be combined. Set the value of "File Name" in "Scan Settings" (page 72). <ul style="list-style-type: none"> • Host Name • Date and Time • User-defined Field • Location

6.4.2 Output File

- Available characters for "User-defined Field"

Lowercase letters	a to z
Uppercase letters	A to Z
Digits	0 1 2 3 4 5 6 7 8 9
Symbols	! # \$ % & ' () + , - ; = @ [] ^ _ ` { } ~

Item delimiter

Underscore	_
Hyphen	-
Off	

Type Code

Output to	Email	FTP	Shared Folder	Cloud	SharePoint	LAN connected computer	USB connected computer
Type Code	M	F	S	C	P	L	U

Sequence ID

The Sequence ID is a 5 digit ID managed for each output destination. One is added upon each scan, and after "99999" it returns to "00001". The sequence ID can be cleared by "11.7 Factory Reset" (page 110).

Image File Limits

Output to	File size, number of pages	Remarks
Email	Up to 5 MB in total or 999 pages.	Email size can be set up to 20 MB. For details, refer to "SMTP" (page 76).
Shared Folder FTP	Up to 512 MB in total or 999 pages.	-

6.4.3 USB mode

Push scan in USB mode is performed by the following procedure.

Register a Job Setting List in Image Capture Plus

1. Start Image Capture Plus.
 - Select [Image Capture Plus Standard] as the application mode.
2. On the [Scan Setting] menu, enable [Job Scan Mode].

Note

- You cannot enable [Job Scan Mode] if any documents are left in [Document List].
3. On the [Scan Setting] menu, click [Job Setting List].
 4. Click [Add] button, and specify the settings.
 5. Click [Save Setting] to save the settings.

Register jobs for USB mode push scan in Image Capture Plus

1. Start Image Capture Plus.
 - Select [Image Capture Plus Standard] as the application mode.
2. On the [Option] menu, click [Application Settings].
3. Select the [Scan Button Settings] tab, and specify the settings.
 - You can register 10 settings for each group.
 - Select the [Job Scan] for "Operation", and then select a job from Job Setting List.
4. Click [OK] to save the settings.

Select [Touch Free Scanning] or [Single Touch Scanning]

- This setting is available for all push scanning in USB mode.
1. Double click the () icon in the notification area of the task bar to open Scan Button Setting Tool.
 - In Windows 8, open Scan Button Setting Tool on the desktop screen.
 2. Select [Touch Free Scanning] or [Single Touch Scanning].

Scan documents

- Operate the scanner as follows.

Note

- If any documents are left in [Document List], Image Capture Plus cannot receive push scan data.

1. Press the Skip/Menu button (▶|) to select USB mode.

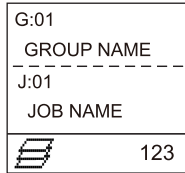

2. Use ◀ or ▶ of the cursor button to select a group, and use ▲ or ▼ to select a job.
 - The Group name and the Job Setting name registered in [Scan Button Settings] are displayed.
3. Place the documents on the feed tray.
 - When [Touch Free Scanning] is selected, scanning will start when documents are placed on the feed tray.
 - When [Single Touch Scanning] is selected, press the OK button or the Start/Stop button (◀/▶) to start scanning.

6.4.4 Network PC mode

Push scan in Network PC mode is performed by the following procedure.

Configure the network settings

1. You should configure the network settings using the LCD on the unit, Network Setting Tool, and Configuration Web.

Add the scanner to the computer that will receive scanned data

1. Start Network Scanner Select Tool on the computer that will receive scanned data.
2. Add the scanner to the list.
3. Click [OK].
 - The scanner can select the computer as the destination.

Register Jobs in Image Capture Plus on the computer that will receive scanned data

1. Start Image Capture Plus.
 - Select [Image Capture Plus Standard] as the application mode.
2. On the [Scan Setting] menu, enable [Job Scan Mode].
 - You cannot enable [Job Scan Mode] when any documents are left in [Document List].
3. On the [Scan Setting] menu, click [Job Setting List].
4. Click [Add] button, and specify the settings.

Note

- When using Network PC Mode, Touch Free Scanning is not available.
- The top 10 jobs in the job settings list are available for Network PC Mode.

Scan documents

- If any documents are left in [Document List], Image Capture Plus cannot receive push scan data.
 - Operate the scanner as follows.
1. Press the Skip/Menu button (▶|) to select network PC mode.

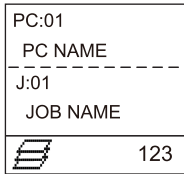

2. Use ◀ or ▶ of the cursor button to select a computer.
 - By pressing the OK button, you can check the IP address of the currently selected computer. By pressing the OK button again, you can return to the original screen.
3. Use ▲ or ▼ of the cursor button to select a job.
 - You can select a job from the top 10 jobs in job settings list.
4. Place the documents on the feed tray.
5. Press the Start/Stop button (◀/▶) to start scanning.

6.4.5 Preset Scan mode

Push scan in preset scan mode is performed by the following procedure.

Configure the network settings

1. You should configure the network settings using the LCD on the unit, Network Setting Tool, or Configuration Web.
2. Set up a scan server as necessary
 - Depending on the functions you want to use during scanning, you may need to set up a scan server. If you will use "Cloud" or "SharePoint" as output destinations, you must set up a scan server. For details, refer to "7.1 Functions that require a scan server" (page 64).
 - For details about setting up a scan server, refer to "7.2 How to set up the scan server" (page 65).

Configure the scanning conditions using Configuration Web

1. Launch Configuration Web.
 - For details, refer to "8.1 Launch Configuration Web" (page 66).
2. Open the Server tab and configure the settings that you will use. For details, refer to "8.7 Server tab" (page 76).
 - If you use e-mail, you should configure SMTP Settings.
 - If you use shared folders, you should configure Shared Folder List.
 - If you use FTP, you should configure FTP Server List.
3. Open the Scan tab.
4. Open the [Scan Settings] sub menu.

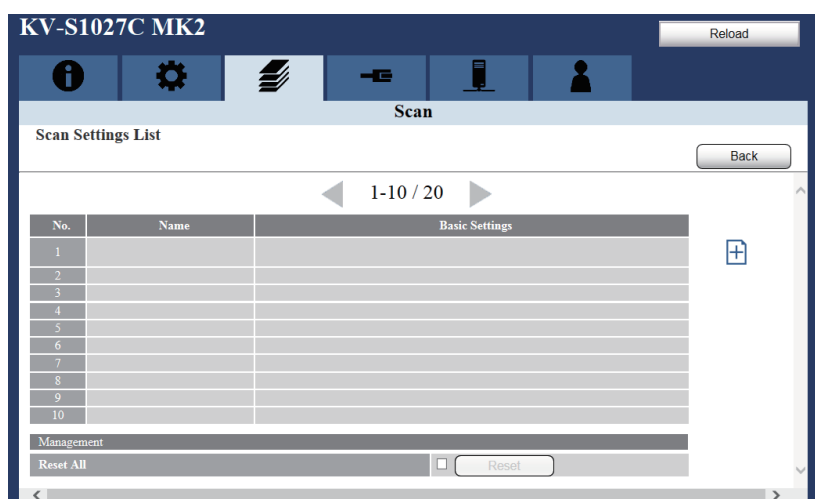

- You can register up to 20 settings.
5. Click  to register a setting.
 6. Set the Scan Settings as needed. For details, refer to "Scan Settings" (page 72).

6.4.5 Preset Scan mode

- Click [Submit] to apply the settings, and then click [Back].

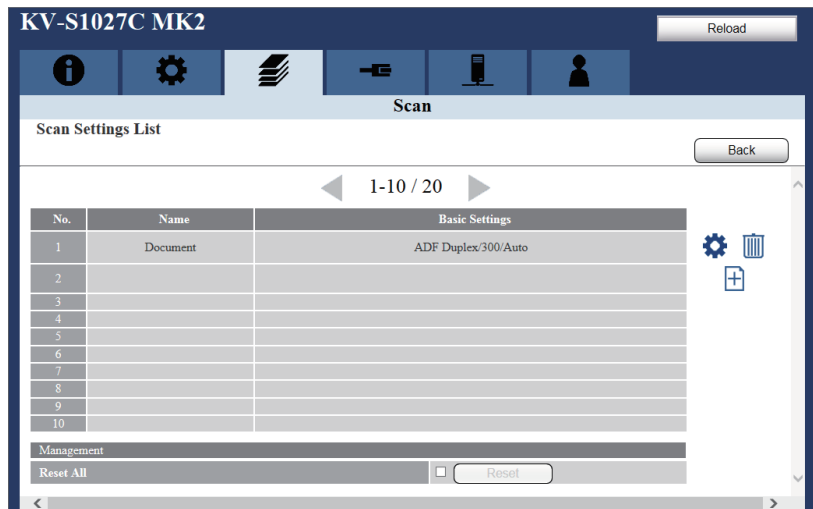

- Open the [Preset Scan] sub menu.

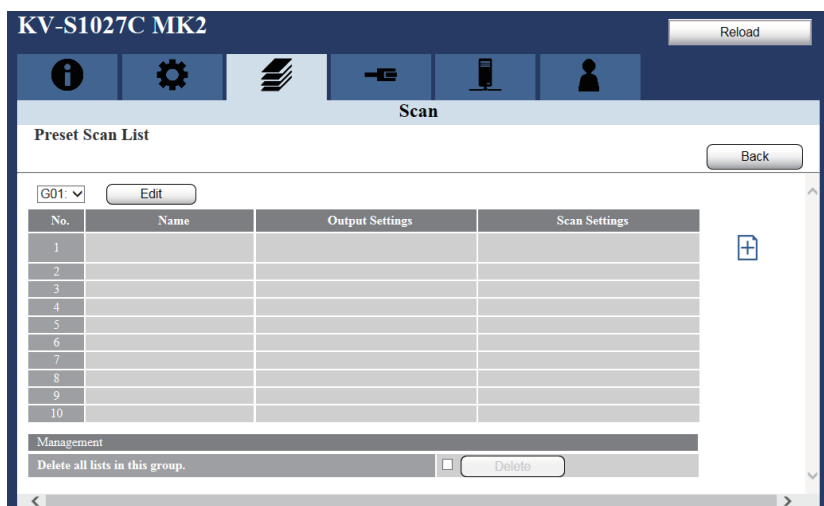

- You can register up to 30 settings in total. (3 groups, 10 settings for each group.)

- Click  to register a setting.

10. Register the scan settings as needed.

Output Settings

- Select [Email], [Shared Folder], [FTP], [Cloud] or [SharePoint] as the output method.
- If Shared Folder or FTP is selected as the output destination, a folder path from the list registered in the Server tab should be selected.
- If "Cloud" or "SharePoint" is selected as the output destination, a folder path configured within the Image Capture Plus should be selected.

Scan Settings

- Select the setting from Scan Settings List.
- You can register the setting on this screen, too.

Note

If you need to change the advanced settings, click  in [Advanced Settings].

11. Click [Submit] to apply the settings, and then click [Back].



- Make sure the list has been added.

Scan the documents

- Operate the scanner as follows.
1. Press the Skip/Menu button () to select Preset Scan mode.

★:1	

PS:01	
PRESET NAME	
	123

2. Use ◀ or ▶ of the cursor button to select a Preset Group.
3. Use ▲ or ▼ of the cursor button to select a Preset Scan setting list.
4. Place the documents on the feed tray.
5. Press the Start/Stop button () to start scanning.
 - If [Confirm Output Path] of Preset Scan setting is enabled, the output path will be displayed on the LCD. Confirm the output path, and then press the Start/Stop button () again.
 - If [Confirm Output Path] of Preset Scan setting is disabled, scanning will start.

7 Scan Server

7.1 Functions that require a scan server

When scanning over the network, it is necessary to install a scan server in order to use some functions. If a scan server is not configured, the scanned data is sent directly to the output destination.

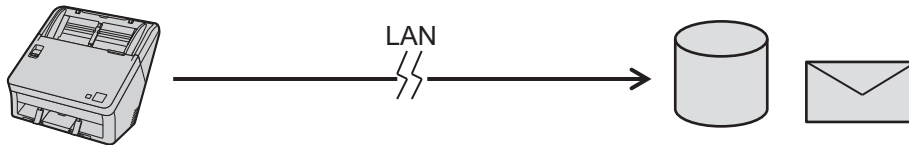

If a scan server is configured, the scanned data is sent to the destination via the scan server if necessary. The scan server will run automatically in the background. Therefore, you do not need to select a scan server when scanning.



To set up a scan server, you need the option CD-ROM [KV-SS094]. If you use the enclosed Software / Manual CD-ROM without using the option CD-ROM [KV-SS094], some functionality will be restricted. For details, refer to "11.1 Available Functions When Scanning" (page 101).

Note

- The PC used as a scan server must always be running and have a user logged in. Please do not use the sleep or energy-saving functions.
- Set up a dedicated computer to operate as the scan server.
- You must set up a scan server to set "Output to" to "Cloud" or "SharePoint".
- When using "Email" / "FTP" / "Shared Folder" as the output destination, some functions become available when you install Scan Server. For details, refer to "11.1 Available Functions When Scanning" (page 101).
- A scan server is not necessary in the following cases.
 - The output destination is a LAN-connected computer.
 - Pull scan
- To make advanced settings for cloud output or SharePoint output, run Image Capture Plus and perform the following steps on the screen that is displayed.
 - In case of Cloud output:** (up to 50 settings)
 - [Option] → [Scan To PC Settings / Scan Server Settings...] → [Scan Server Setting - Cloud...].
 - In case of SharePoint output:** (up to 50 settings)
 - [Option] → [Scan To PC Settings / Scan Server Settings...] → [Scan Server Setting - SharePoint...].

7.2 How to set up the scan server

Using the option CD-ROM [KV-SS094]

1. Insert the option CD-ROM [KV-SS094] into the CD/DVD drive of the computer you want to set up as the scan server.
 - The setup window will appear.
 - If the AutoPlay dialog box is displayed, select [CDRun.exe].
 - If the setup window does not appear, double-click [CDRun.exe] in the option CD-ROM [KV-SS094].
2. Follow the instructions on the screen and complete the installation.
 - To install the option CD-ROM [KV-SS094], you need to enter the serial number.
 - The serial number is included on the packaging of option CD-ROM [KV-SS094].
3. Start Scan Server Setting Tool as follows.
 - Select [All Programs] → [Panasonic] → [Scanner Tools] → [Scan Server Setting Tool].

Note

In Windows 8 and Windows 10, select the [Panasonic Document Scanner] section on the Apps screen.

4. Set the computer as the scan server.
 - "License: Installed" is displayed.
5. Set up the computer as the scan server for each scanner.
 - For details, refer to the help of the Scan Server Setting Tool.

Using the Software / Manual CD-ROM

There are some restrictions on the available functions (page 101).

1. Insert the Software / Manual CD-ROM into the CD/DVD drive on your computer.
 - If the AutoPlay dialog box is displayed, select [CDRun.exe].
 - If the setup window does not appear, double-click [CDRun.exe] in the Software / Manual CD-ROM.
 - When the model selection screen is displayed, select the correct model to use.
2. Select [Complete].
3. Follow the instructions on the screen and complete the installation.
4. Start Scan Server Setting Tool as follows.
 - Select [All Programs] → [Panasonic] → [Scanner Tools] → [Scan Server Setting Tool].

Note

In Windows 8 and Windows 10, select the [Panasonic Document Scanner] section on the Apps screen.

5. Set the computer as the scan server.
 - "License: Not installed" is displayed.
6. Set up the computer as the scan server for each scanner.
 - For details, refer to the help of the Scan Server Setting Tool.

8 Using Configuration Web

Network settings for this unit can be configured using the web browser that was launched from Network Scanner Select Tool.

Note

- Some settings can also be configured using the LCD on the unit (page 28).
- If you are using Internet Explorer 11 and "Display intranet sites in Compatibility View" is selected, Configuration Web may not be displayed correctly.

8.1 Launch Configuration Web

1. Start Network Scanner Select Tool.
2. Select the desired scanner.

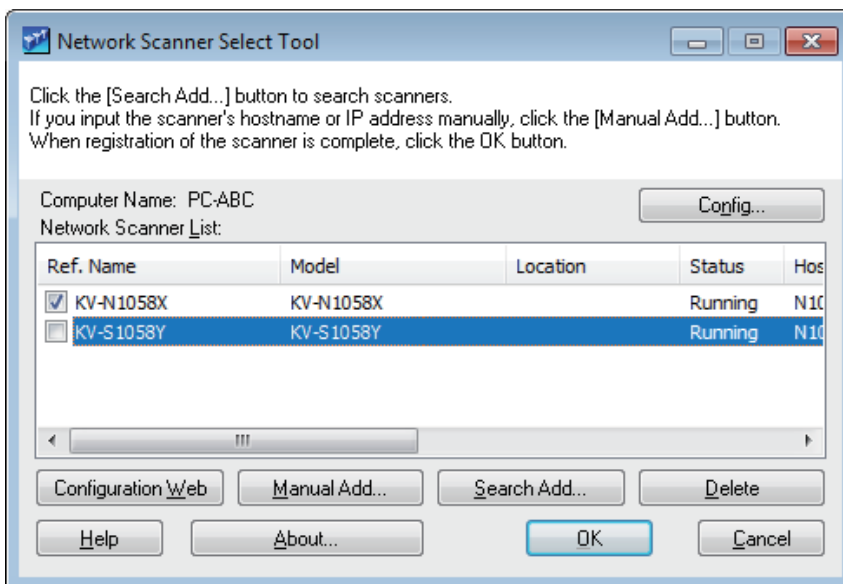

Note

- Select the check box of the scanner you use for pull scan.





3. Click [Configuration Web].
 - The web browser will launch.

Notice

- To use Configuration Web, except for the Information tab, "User Name" and "Password" are necessary. Set "User Name" and "Password" when the password setting screen appears. For details about the password, refer to "Password Settings" (page 79).

8.2 Basic Browser Operations

- To operate the browser, refer to the following.

	Operation	Remarks
[Reload]	Update the display.	-
[Submit]	Apply the settings.	You must click [Submit] to change the settings.
[Back]	Return to the original screen from a sub menu.	-
[Test]	Test whether connection to the server is possible with the current settings of "SMTP" (page 76), "Shared Folder" (page 76), "FTP" (page 77) or "7 Scan Server" (page 64) .	The test results are displayed. In "SMTP" connection test, email has been sent to the input mail address.
	Open the editing screen for the list.	-
	Delete the list.	-
	Add a list.	-
	Display other lists.	-

Note

- To apply the settings, click [Submit] within 30 minutes after editing the settings. After 30 minutes, you must click [Reload] and edit the settings again.

8.2.1 Available characters in Configuration Web

You can enter the following characters in Configuration Web.

Lowercase alphabet	a to z
Uppercase alphabet	A to Z
Digit	0 1 2 3 4 5 6 7 8 9
Symbol	! " # \$ % & ' () * + , - . / : ; < = > ? @ [\] ^ _ ` { } ~

Note

- Double-byte character can be used in shared folder paths.
- The following symbols cannot be used in folder paths.

Shared Folder	* / < > ?
FTP	" * , ; < > ?

- Refer to "Available characters for "User-defined Field"" (page 56) for the list of valid characters that can be entered in "User-defined Field" of the output file name.

Available characters for "Host Name"

Lowercase letters	a to z
Uppercase letters	A to Z
Digits	0 1 2 3 4 5 6 7 8 9
Symbols	-

Available characters for "Location"

Lowercase letters	a to z
Uppercase letters	A to Z
Digits	0 1 2 3 4 5 6 7 8 9
Symbols	! # \$ % & ' () + , - ; = @ [] ^ _ ` { } ~

8.3 Information tab

Display basic status and information of the unit.

Scanner

The screenshot displays the 'KV-S1027C MK2' web interface with the 'Information' tab selected. The 'Scanner' sub-tab is active, showing the following data:

Scanner Status	
Scanner Status	Sleep
Error Code	-
Network	1Gbps #220
Date & Time	2017/01/01 0:00
Scanner Information	
Model Name	KV-S1027C MK2
Firmware Version	T.70
Scan Counter	
System	0
Scan	0

Network

The screenshot displays the 'KV-S1027C MK2' web interface with the 'Information' tab selected. The 'Network' sub-tab is active, showing the following data:

Information	
MAC Address	
Host Name	
IP Address	
DHCP	On
AutoIP	On
IP Address	
Subnet Mask	
Default Gateway	
DNS Server	
Primary	
Secondary	
WINS Server	
Primary	
Secondary	

8.4 Function tab

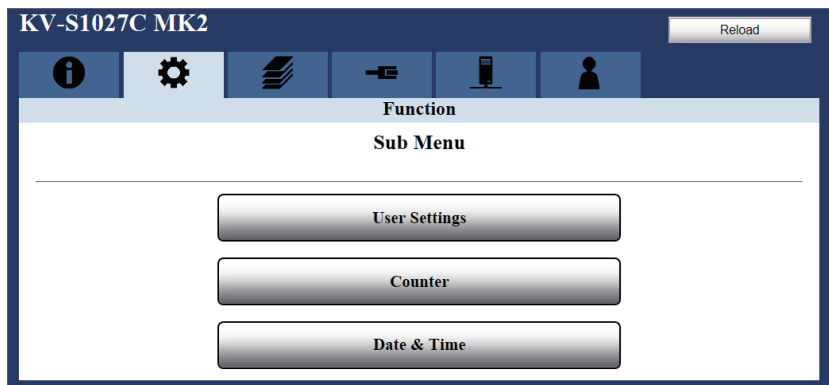

Set the basic functions and maintenance functions of the unit.

User Settings

Item	Contents
USB ID	Display the scanner's USB serial number.
Language	Set the language used on the LCD and Configuration Web.
Sleep	Set the time length before the unit enters sleep mode. (1 to 120 min.)
Power Off	Set the power auto-off function. (15 min. to 72 hrs.)
Roller Cleaning Notification	Enable (On) or disable (Off) the settings.
Roller Replacement Notification	
Glass Cleaning Notification	
Select Counter	Selects whether the [Scan] counter or the [System] counter is displayed on the LCD during scanning.
Date Format	Select a date format from YYYYMMDD, MMDDYYYY or DDMMYYYY.
Time Format ^{*1}	Select a time format from 12H or 24H.

*1 Only displayed when the display language is English.

Counter

Item	Contents
Scan	The number of documents scanned during the scanning process. This counter is cleared each time you start scanning.
System	The number of documents scanned by the scanner since it was shipped from the factory.
After Clean Roller Counter	The number of documents scanned since clearing the counter after cleaning the rollers. Clear after cleaning the rollers.
After Replace Roller Counter	The number of documents scanned since clearing the counter after replacing the rollers. Clear after replacing the rollers.
Clean Roller Timing	You can change the number of documents scanned before the Roller Cleaning Notification occurs, if necessary.
Replace Roller Timing	You can change the number of documents scanned before the Roller Replacement Notification occurs, if necessary.

Date & Time

Item	Contents
Date and time setting	If "Use the PC clock." is selected, the scanner will get the date and time from the computer when you click [Submit]. After you click [Submit], the check box is cleared automatically.
Date	Select a value from the list.
Time	Select a value from the list.
Time Zone	Set your time zone.

8.5 Scan tab

Register scanning conditions for Preset Scan (Push scanned data to FTP, Shared Folder, or Email).

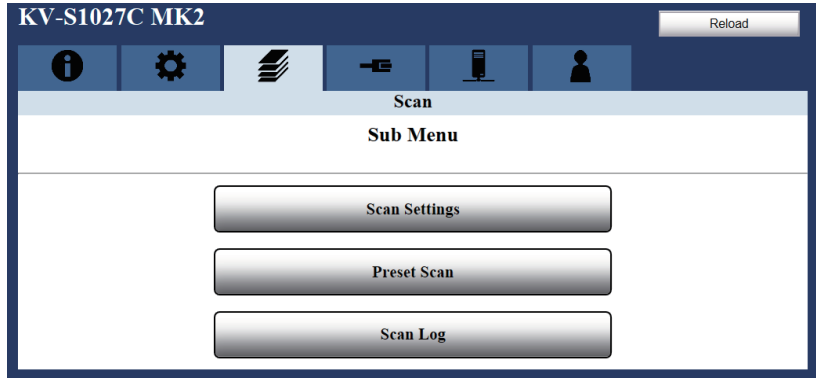

Scan Settings

Item	Contents
Basic Setting	Name (up to 15 characters) / Paper Source / Paper Size / Image Type / Resolution
Advanced Settings	Dynamic Threshold / Automatic Brightness Adjustment / Brightness / Contrast / Deskew / Rotate / Blank Page Removal / Noise Reduction / Border Removal / Hole Removal / Smooth Background / Background Removal / Detect Double Feed / Barcode / Continue Scan
File Type	PDF / TIFF / JPEG / PDF/A / PDF (Searchable) File / PDF/A (Searchable) File
PDF Password	Set PDF password function (On / Off).
Password	Set PDF password (0 to 8 characters).
JPEG Quality	Sets the JPEG quality (Low / Normal / High).
High-compression	Set high compression (On / Off).
File Setting	Select file setting (Single Page / Multi Page).
Language	Select language used for searchable PDF.
Page Number	Sets searchable page range (1 to 9999) of searchable PDF.
File Name	Sets the file name (Host Name / Date & Time / User-defined Field ^{*1} (up to 15 characters) / Location (up to 31 characters) / Combination (up to 78 characters)).
Item delimiter	Underscore / Hyphen / Off
User-defined Field	A user-defined string to use as the file name ^{*1} (up to 15 characters).
Management	Reset the list.

*1 Refer to "Available characters for "User-defined Field"" (page 56) for the list of valid characters that can be entered in "User-defined Field" of the output file name.

Preset Scan

Item	Contents
Group name	Select group G01 to G03 and edit group name (up to 15 characters).
Management	Delete all lists in this group.
Index	Set the name of this preset (up to 15 characters).
Output Settings	Sets the Output Method. Email: To (1) / To (2) / To (3) / To (4) / To (5) / Subject / Comment (up to 15 characters) ^{*1} Shared Folder: Output Path FTP: Output Path Cloud: Destination SharePoint: Destination
Scan Settings	Refer to "Scan Settings" (page 72).
Confirm Output Path	Sets the confirmation message (On / Off) when start scanning.

*1 The scanner's host name will be used for the email subject. You can append additional text to the host name for the subject.

Scan Log

You can confirm the preset scan log.

8.6 Network tab

Register network settings.

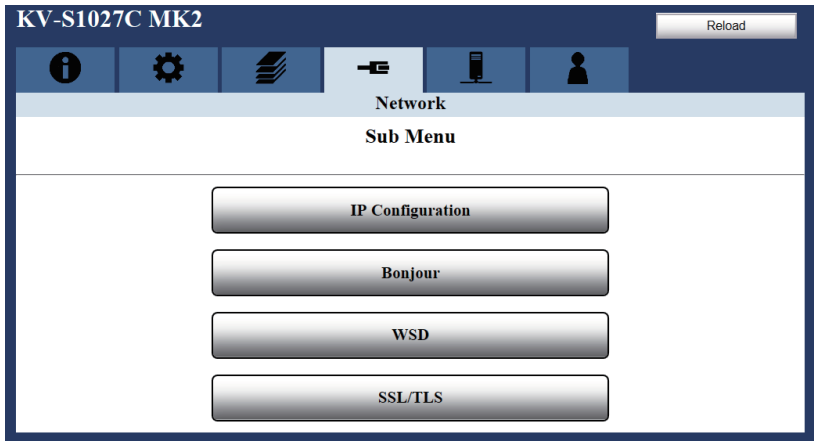

IP Configuration

Item	Contents
Network Setting	MAC Address / Host Name ¹ / Location ² (up to 31 characters)
IP Address	DHCP / AutoIP / IP Address / Subnet Mask / Default Gateway
DNS Server	Primary / Secondary
WINS Server	Primary / Secondary
Firewall	IP Filtering / Filter (IPv4)

¹ The default host name is "model name_part of MAC address". This name must be unique. Refer to "Available characters for "Host Name"" (page 68) for the list of valid characters that can be entered in "Host Name".

² You can input a location note. Refer to "Available characters for "Location"" (page 68) for the list of valid characters that can be entered in "Location".

Bonjour

Item	Contents
Service	Enable (On) or disable (Off) the service.
Service Name	Set the Bonjour service name (up to 63 characters).

WSD

Item	Contents
Service	Enable (On) or disable (Off) the service.

SSL/TLS

Item	Contents
Settings	Setup / Security Level
Certificate	Installation State / Create CRT Key / Self-signed Certificate / Certificate Signed Request / Certificate Installation / Content of Certificate

8.7 Server tab

Register SMTP / Shared Folder / FTP server settings.

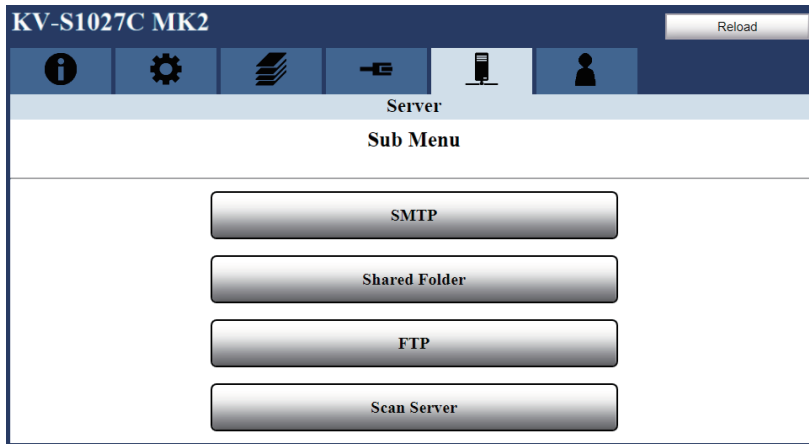

SMTP

Item	Contents
Account	From Address (up to 63 characters)
SMTP Server	Address (up to 63 characters) / SSL/TLS / Port Number
Configuration	Email Size (1 to 20 MB) / Encoding Type / SMTP-AUTH / SMTP User Name (up to 63 characters) / SMTP Password (up to 31 characters) / POP Before SMTP / POP Server Domain Name (up to 63 characters) / POP Port Number / POP User Name (up to 63 characters) / POP Password (up to 31 characters)

Shared Folder

Item	Contents
Shared Folder List	Register Shared Folder (up to 20 folders).
Management	Delete all contents of the displayed lists.
Index	Name (up to 15 characters)
Account	Domain/Workgroup (up to 63 characters) / User (up to 20 characters) / Password (up to 31 characters)
Folder Path	Path (up to 255 characters)

FTP

Item	Contents
FTP Server List	Register FTP Server (up to 10 servers).
Management	Delete all contents of the displayed lists.
Index	Name (up to 15 characters)
FTP Server	Server Address (up to 63 characters) / Protocol ^{*1} / Port Number / Passive Mode / Folder Path (up to 255 characters)
Account	User (up to 31 characters) / Password (up to 31 characters)

*1 "FTP", "FTPS (Explicit)" and "SFTP" are supported. When sending data over FTP, there is a risk of leakage of account information, etc.

Scan Server

Set Computer Name as the Scan Server. For details about the Scan Server, refer to "7 Scan Server" (page 64).

8.8 Administrator tab

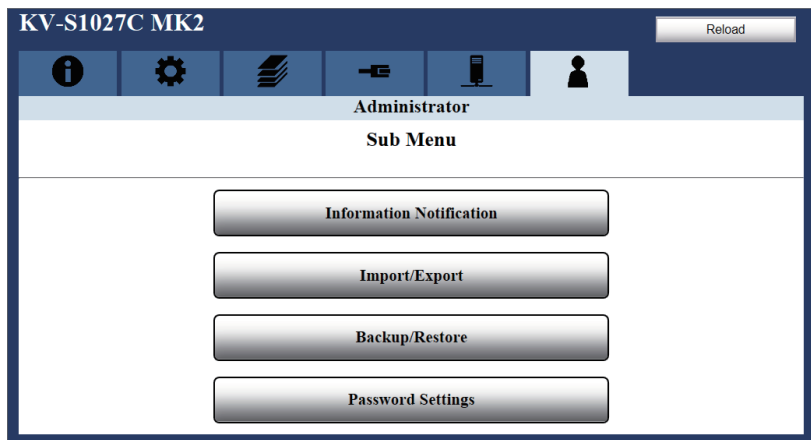

Information Notification

Item	Contents
SMTP Settings	Set the SMTP for notification e-mail.
Information Notification	Enable (On) or disable (Off) the feature.
No.1 / No.2 / No.3	You can set three addresses to send the notifications to about Roller Replacement, Roller Cleaning and System Error.
Information	The last date and time of successful communication from the scanner is displayed.

Import/Export

Item	Contents
Mode	Select mode (Import / Export).
Item	Select item (All Items / Function / Scan Settings / Preset Scan / Network / Server / Information Notification).
File Setting	File Name (up to 255 characters) / Password (0 to 16 characters)

For details, refer to "11.5 Import/Export" (page 108).

Backup/Restore

Item	Contents
Mode	Select mode (Backup / Restore).
File Setting	File Name (up to 255 characters) / Password (0 to 16 characters)

For details, refer to "11.6 Backup/Restore" (page 109).

Password Settings

Item	Contents
User Name	Set the user name (up to 15 characters).
Password	Set the password.

Notice

- Password should meet the following conditions.
 - Use 8 to 16 characters.
 - Use characters from at least 3 of the following categories:

Lowercase alphabet	a to z
Uppercase alphabet	A to Z
Digit	0 1 2 3 4 5 6 7 8 9
Symbol	! " # \$ % & ' () * + , - . / : ; < = > ? @ [\] ^ _ ` { }

- Do not use a password that can easily be guessed.
- The password should be unique. Do not use the same password for other purposes.
- Keep the password secret.
- Change the password periodically.

Note

- If you forget the user name or password, you can reset the user name and the password using Factory Reset (page 110). After Factory Reset, configure the scanner again.

9 Clearing Paper Jams

Torn paper, thin paper or paper that is creased on the top edge may cause paper jams. If a paper jam occurs, remove the jammed sheet according to the following procedure.

1. Remove all documents from the feed tray.
2. Open the ADF door (page 32).
3. Remove the jammed document.
 - If the document is jammed in the feed tray area, pull it backwards as shown in the illustration.

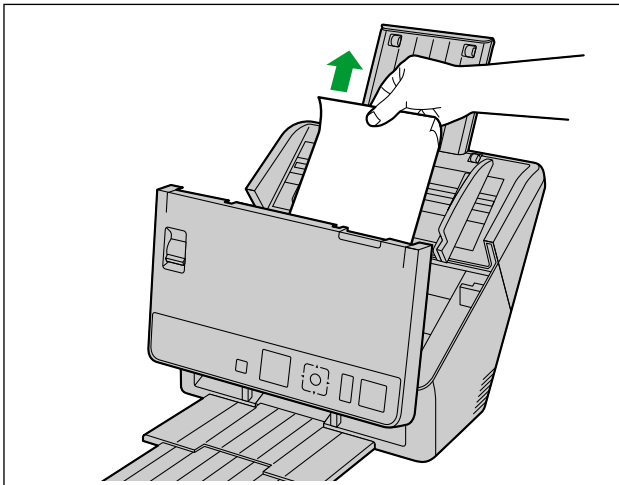

- If the document is jammed in the exit area, pull it forward as shown in the illustration.

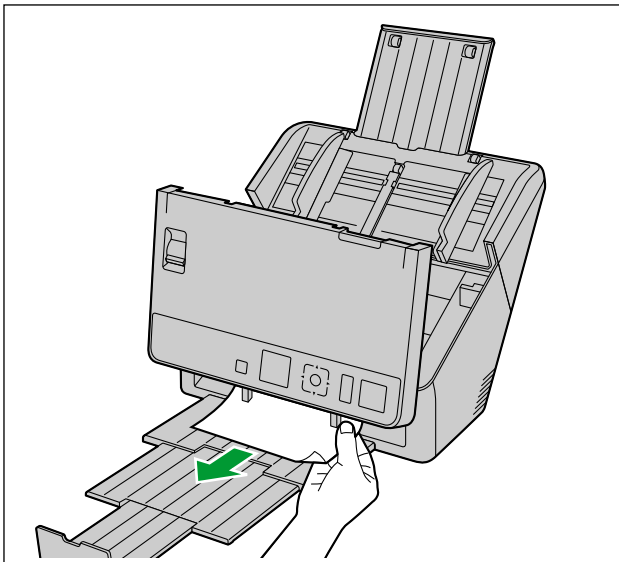

4. Close the ADF door (page 32).

Notice

- Close the ADF door after confirming that no documents remain inside the unit.
- A message is displayed on the screen in push scan. Please follow the instructions. Processing can be selected from the following.
 - Delete the scanned image and stop scanning.

- Transfer the scanned image and stop scanning.
- Transfer the scanned image and continue scanning.

10 Care and Maintenance

10.1 Cleaning the Outside of the Scanner

Notice

- Before moving the unit, be sure to unplug the power cord, USB cable and LAN cable.
- Do not use commercially available cleaners, detergent, thinner, or benzine. (Doing so may cause deformation, discoloration, or damage.)
- Clean the scanner at least once a month.

1. Clean the outside of the scanner with a soft, slightly damp cloth.

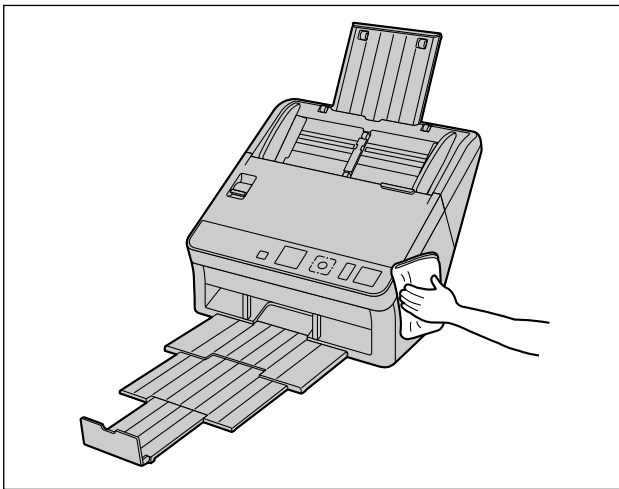

2. Remove dirt and dust from the fan exhaust vent (①) with a brush.

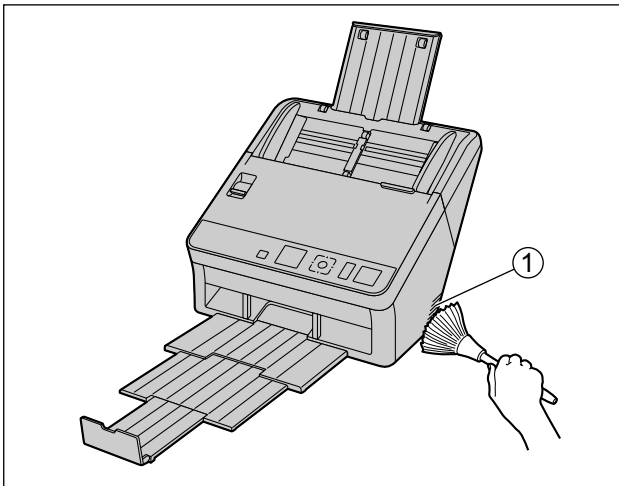

10.2 Cleaning the Inside of the Scanner

Prepare the following cleaning supplies.

Soft and dry cloth (one that does not easily generate fibrous dust)	Used to clean the conveyor and scanning glasses.
Thin cotton swab	Used to clean the double feed detectors and the starting sensors.
Roller cleaning paper (KV-SS03)	Recommended for use in cleaning the rollers. If you do not have the roller cleaning paper, use a soft cloth with a small amount of isopropyl alcohol or water.

Note

- Before cleaning the unit, turn off the unit, and disconnect the power cord, the USB cable and the LAN cable.
 - Clean the inside of the scanner when approximately 8,000 sheets have been scanned. The time for cleaning may differ depending on documents you scan. To maintain proper scanning, clean the scanner parts frequently.
 - Clean the rollers if paper jamming or double feeding occurs frequently.
 - If double feed detection does not function properly, clean the double feed detectors.
 - Clean the scanning glasses when vertical streaks appear on the scanned images.
 - Be careful not to damage any parts of the unit.
 - Do not use flammable aerosol cleaners.
 - Do not use commercially available cleaners, detergent, thinner, or benzene. (Doing so may cause deformation, discoloration or damage.)
1. Open the ADF door (page 32).
 2. Clean the conveyor, scanning glasses, double feed detectors, starting sensors and rollers.
 - Clean the parts in the following order: conveyor and scanning glasses, double feed detectors and starting sensors, rollers.
 - For details about cleaning, refer to the following sections:
 - "10.2.1 Cleaning the Conveyor and Scanning Glasses" (page 84)
 - "10.2.2 Cleaning the Double Feed Detectors and Starting Sensors" (page 85)
 - "10.2.3 Cleaning the Rollers" (page 86)
 3. Close the ADF door (page 32).
 4. Turn ON the unit's power (page 31).
 5. Set the After Clean Roller Counter to zero (0).
 - For details, see "10.2.5 Clearing the Counter After Cleaning the Rollers" (page 93).

10.2.1 Cleaning the Conveyor and Scanning Glasses

1. With a soft and dry cloth, wipe off any dirt on the conveyor (①) and scanning glasses (②).
 - If the dirt does not come off, use a soft, slightly damp cloth.

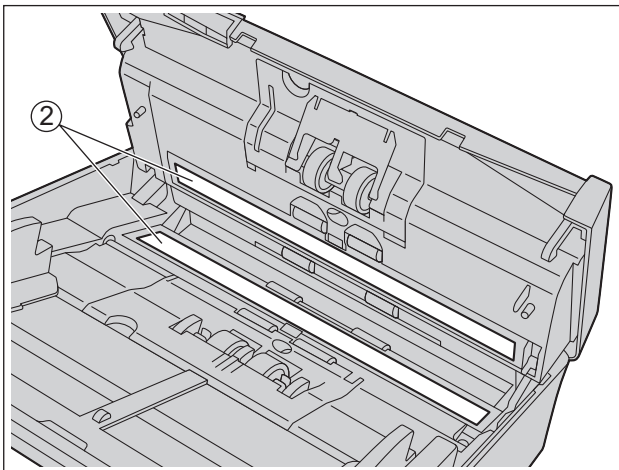
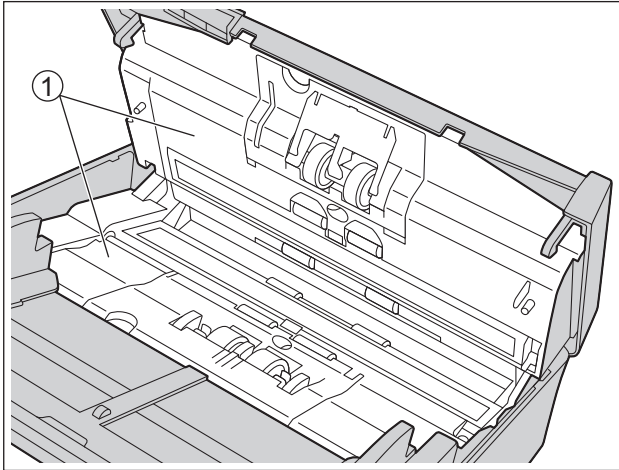

10.2.2 Cleaning the Double Feed Detectors and Starting Sensors

1. Remove dust from the double feed detectors (①) and starting sensors (②) with a cotton swab.

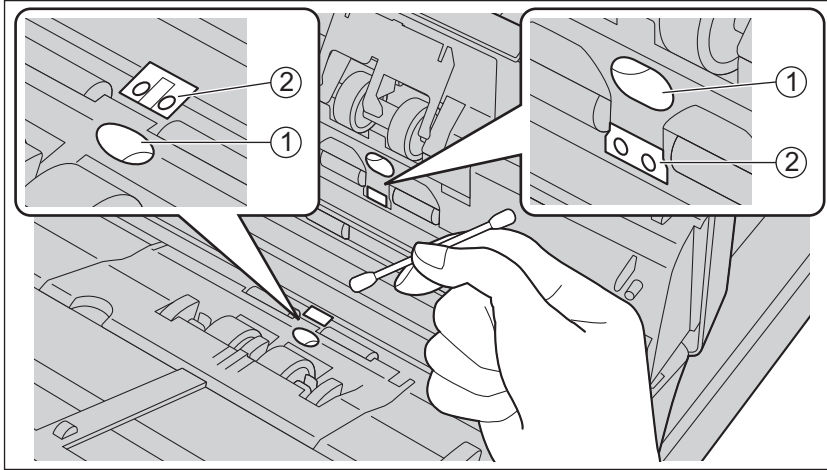

10.2.3 Cleaning the Rollers

Use the roller cleaning paper (KV-SS03) (page 13) to wipe dirt off from the surfaces of all rollers.

Notice

- Be careful not to damage any parts of the unit.

1. Open the double feed prevention roller cover (①).

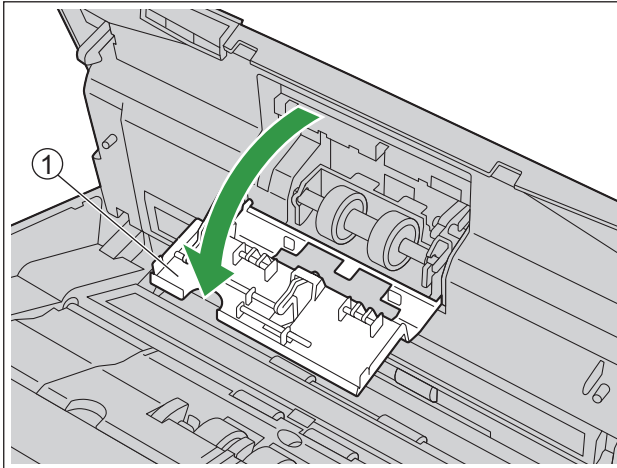

2. Remove the double feed prevention roller.

- While pushing the latch (①) to the right side as indicated by the arrow, remove the double feed prevention roller (②) in the direction of the arrow. Then, pull out the left shaft (when facing it) from the notch in the roller mount.

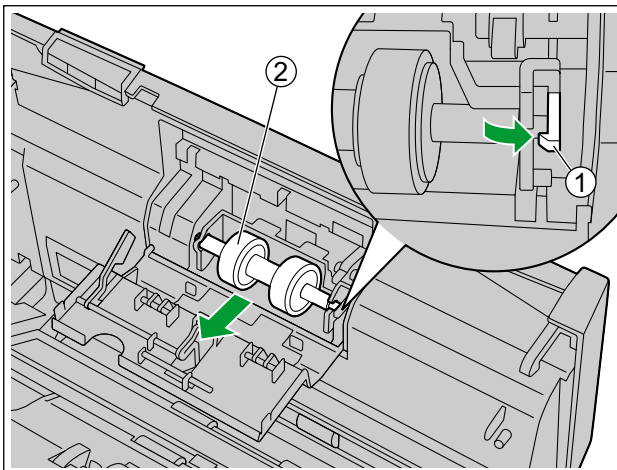

3. Use the roller cleaning paper to clean the surface of the double feed prevention roller.
 - Wipe the entire surface of both rollers.

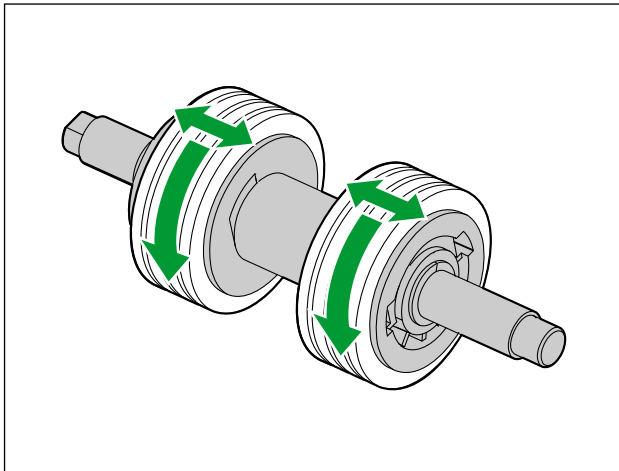

4. Install the double feed prevention roller.
 - Align the shaft that is shaped as indicated by ① with the notch in the roller mount (②), and then insert the shaft in the notch. Push the shaft on the opposite side (③) until it clicks into place.

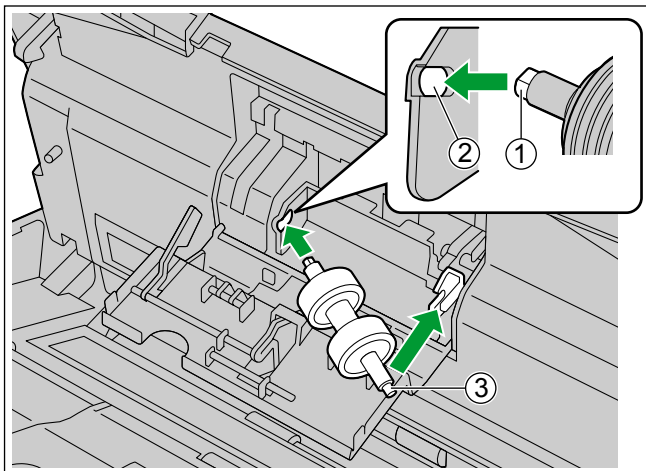

10.2.3 Cleaning the Rollers

5. Close the double feed prevention roller cover (①) firmly.

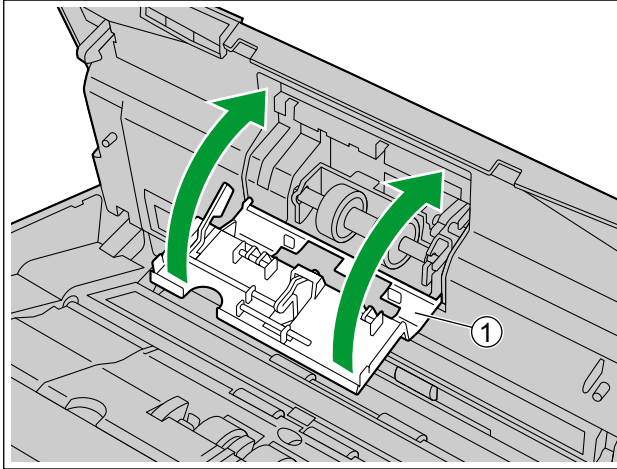

Notice

- Be sure to close the double feed prevention roller cover until it clicks into place.

6. Open the paper feed roller cover (①).

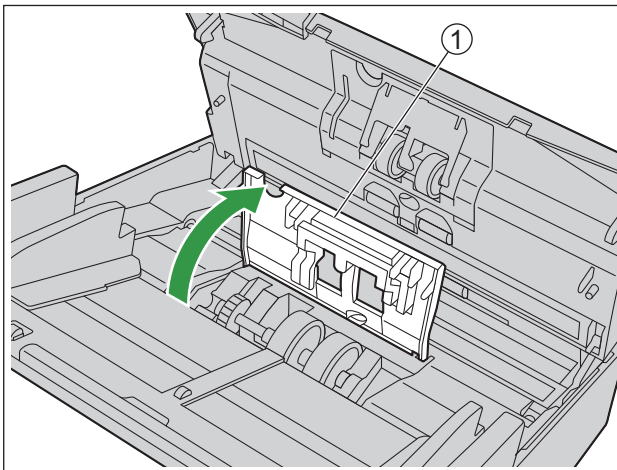

7. Use the roller cleaning paper to clean the paper feed roller.
 - Wipe the rollers from one end to the other (in the direction of the arrow) all the way around them, as shown in the illustration.

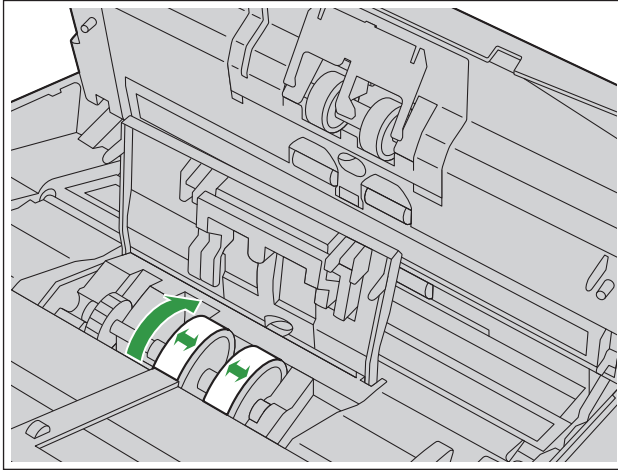

8. Close the paper feed roller cover firmly.
 - Make sure to close both sides of the paper feed roller cover until they click into place.

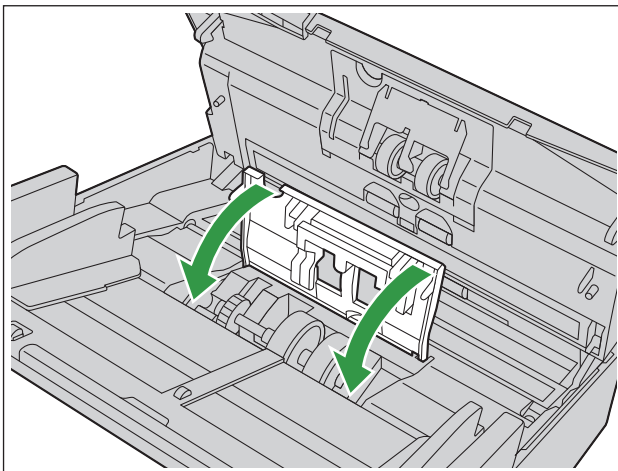

9. Clean the conveyor rollers and exit rollers. For details, see "10.2.4 Cleaning Mode" (page 91).

10.2.3 Cleaning the Rollers

10. Use the roller cleaning paper to clean the surface of the free rollers (①).

- Wipe the rollers from one end to the other (in the direction of the arrow) all the way around them, as shown in the illustration. Use your finger to rotate the roller and wipe dirt off of the entire surface of the roller.

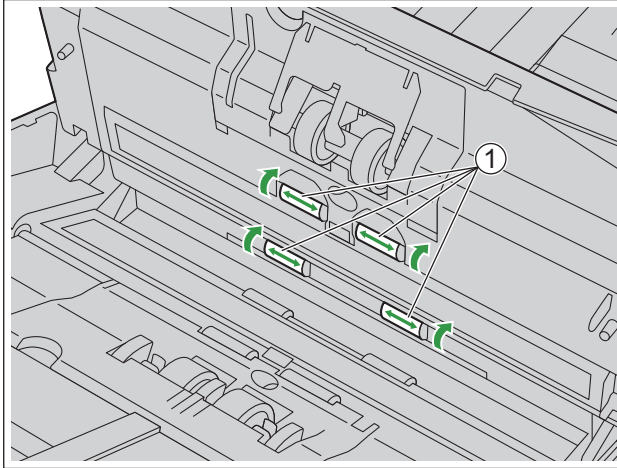

Note







- If misfeeding or double feeding occurs after cleaning or replacing the rollers, the rollers may not be installed properly. Confirm the installation conditions again.

10.2.4 Cleaning Mode

Cleaning Mode can be used to help clean the conveyor rollers and the exit rollers. During Cleaning Mode, the conveyor rollers and the exit rollers rotate a small amount every time the Start/Stop button () on the scanner is pressed. So you do not have to rotate the conveyor rollers and the exit rollers by using your fingers in order to clean the entire surface of each roller.

Notice

- Do not touch the rollers while they are rotating.
- Use Cleaning Mode only to clean the conveyor rollers and exit rollers.

1. Close the ADF door (page 32).
2. Plug in the power cord.
3. Turn ON the unit's power (page 31).
4. Press and hold the Skip/Menu button () for 1 second or more.
5. Use  or  of the cursor button to select "Maintenance".
6. Press the OK button to complete your selection.
7. Use  or  of the cursor button to select "Cleaning Mode".
8. Press the OK button to complete your selection.
 - Cleaning Mode will start.
9. Open the ADF door (page 32).
10. Clean the conveyor rollers (①) and exit rollers (②).
 - i. Use the Roller Cleaning Paper (page 13) to wipe the rollers from one end to the other (in the direction of the arrow) all the way around them, as shown in the illustration.
 - ii. Press the Start/Stop button () on the scanner to rotate the rollers a small amount.
 - iii. Repeat these steps until all surfaces of all rollers are cleaned.

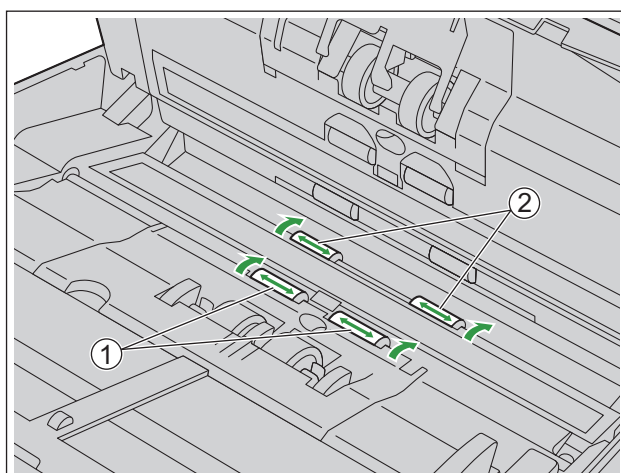

11. Close the ADF door (page 32).
12. Press the Skip/Menu button () to exit Cleaning Mode.

Note

- Cleaning Mode can also be started from User Utility. For details, refer to the User Utility help.

10.2.5 Clearing the Counter After Cleaning the Rollers

After cleaning the rollers, set the After Clean Roller Counter to zero (0) from the operation panel (page 25).

1. Press and hold the Skip/Menu button (▶|) for 1 second or more.
2. Use ▲ or ▼ of the cursor button to select "Counter".
3. Press the OK button to complete your selection.
4. Use ▲ or ▼ of the cursor button to select "Clear Clean Roller Counter".
5. Press the OK button to complete your selection.

10.3 Replacing the Rollers

As a rough guideline, we recommend replacing the paper feed roller and double feed prevention roller module after scanning 250,000 sheets of paper. ("250,000 sheets" is based on scanning high-quality woodfree paper. Depending on the type of paper and other factors, the actual lifetime of the rollers may be shorter.)

You can check the number of sheets that have been scanned. Refer to "5.3 Menu screen" (page 28).

Notice

- Be careful not to damage any parts of the unit.

1. Turn OFF the unit's power (page 31).
2. Open the ADF door (page 32).
3. Open the double feed prevention roller cover (①).

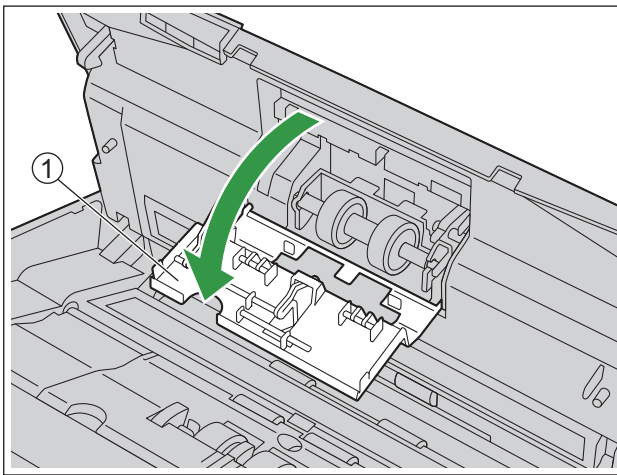

4. Remove the double feed prevention roller.

- While pushing the latch (①) to the right side as indicated by the arrow, remove the double feed prevention roller (②) in the direction of the arrow. Then, pull out the left shaft (when facing it) from the notch in the roller mount.

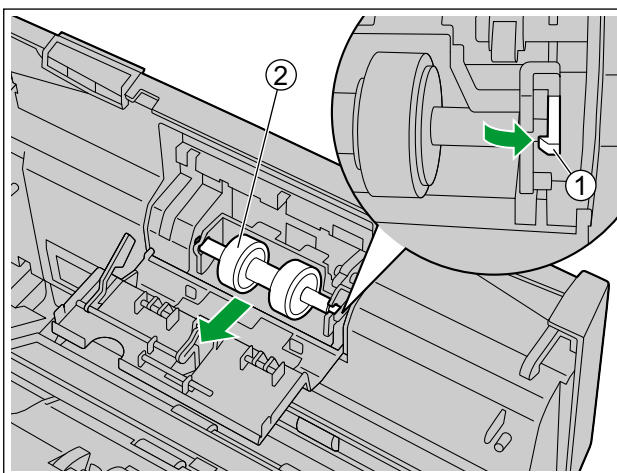

5. Take out the new double feed prevention roller module in the optional roller exchange kit.

6. Install the double feed prevention roller.

- Align the shaft that is shaped as indicated by ① with the notch in the roller mount (②), and then insert the shaft in the notch. Push the shaft on the opposite side (③) until it clicks into place.

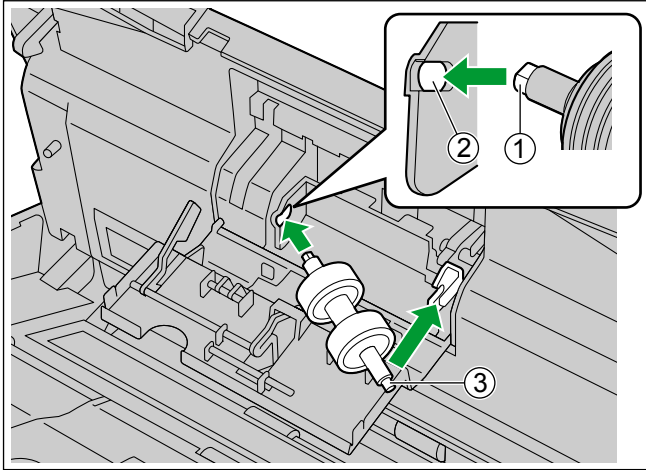
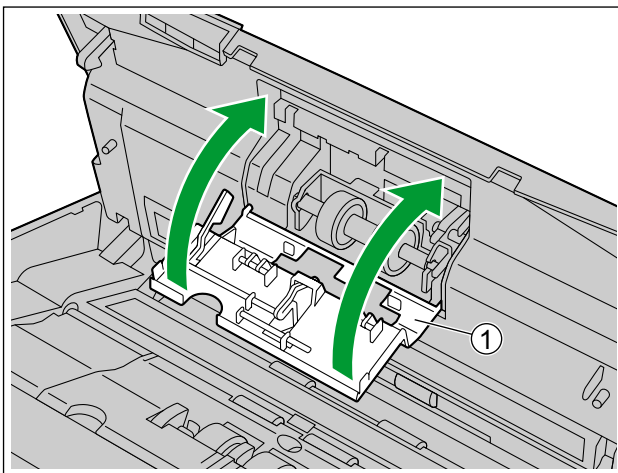
**7.** Close the double feed prevention roller cover (①) firmly.**Notice**

- Be sure to close the double feed prevention roller cover until it clicks into place.

10.3 Replacing the Rollers

8. Open the paper feed roller cover (①).

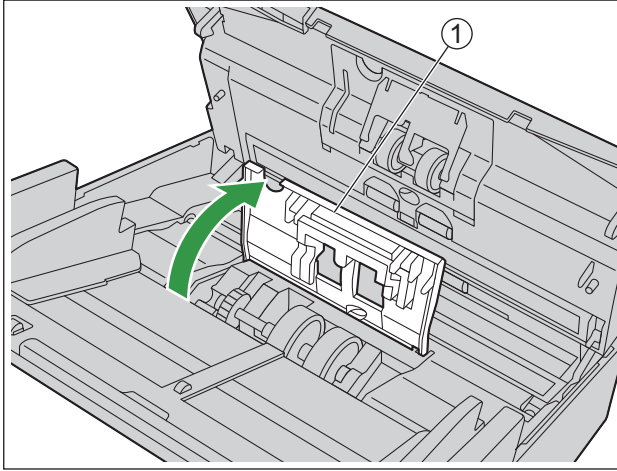

9. Lift up the gear (①) on the left side of the paper feed roller, and then remove the paper feed roller.

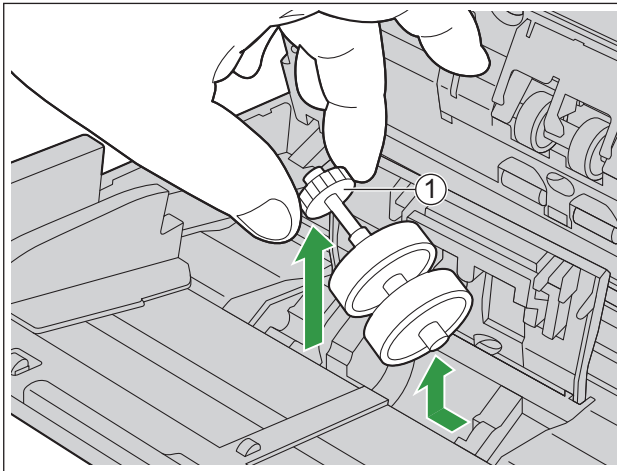

10. Remove the rubber rollers from the paper feed roller shaft.

- Push the tab (1) to remove the rubber roller (2) from the paper feed roller shaft. Remove the other rubber roller (3) in the same way.

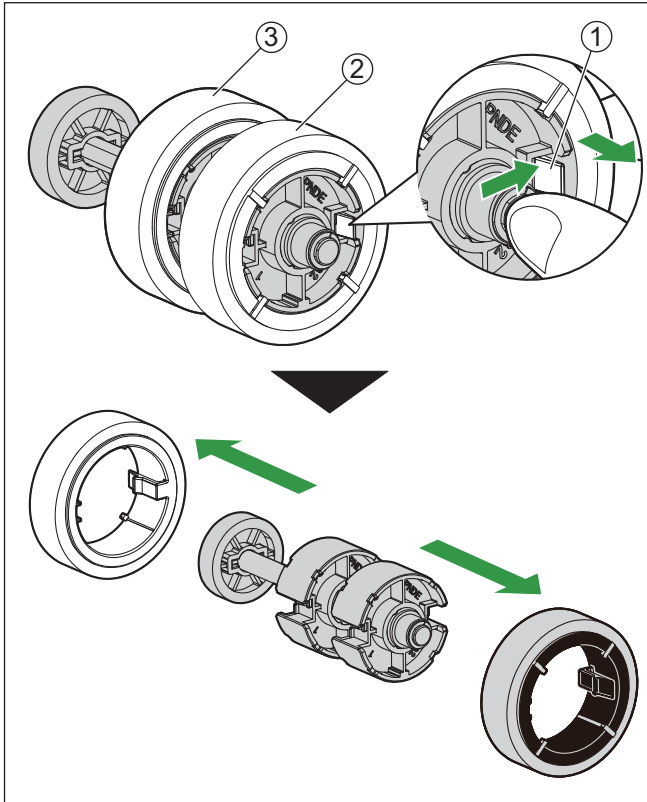

11. Take out the new paper feed rollers in the optional roller exchange kit.

10.3 Replacing the Rollers

12. Install the two new rubber rollers onto the paper feed roller shaft.

- Make sure the left (① white) and right (② black) paper feed rollers are installed correctly.
- After confirming the tabs (③) of both rubber rollers are facing outwards, insert the rubber rollers onto the paper feed roller shaft until they click into place.

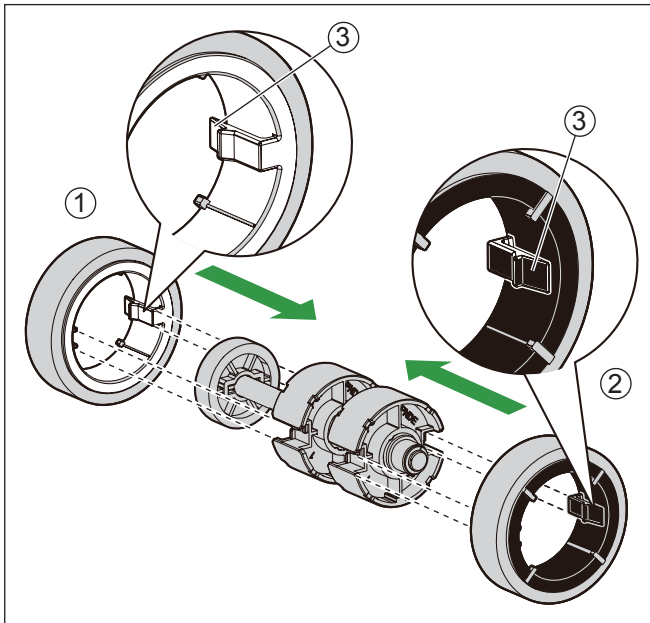

Notice

- Inserting a rubber roller with the tab facing inwards may damage the roller.

13. Install the paper feed roller with the new rubber rollers.

- Insert the short side of the paper feed roller shaft (①) to the roller mount, and then insert the gear (②) in the direction indicated by the arrow.

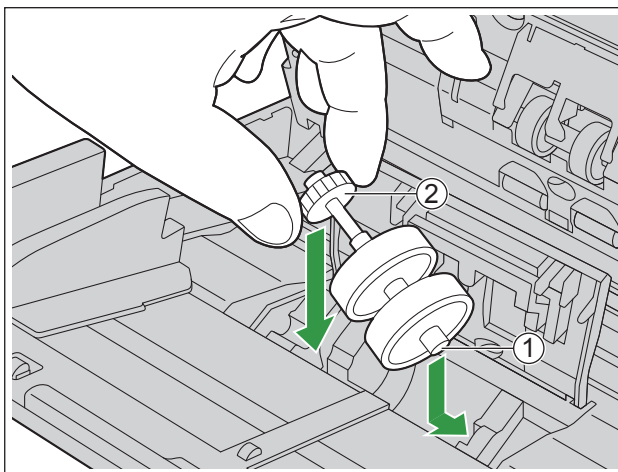

14. Close the paper feed roller cover (1) firmly.

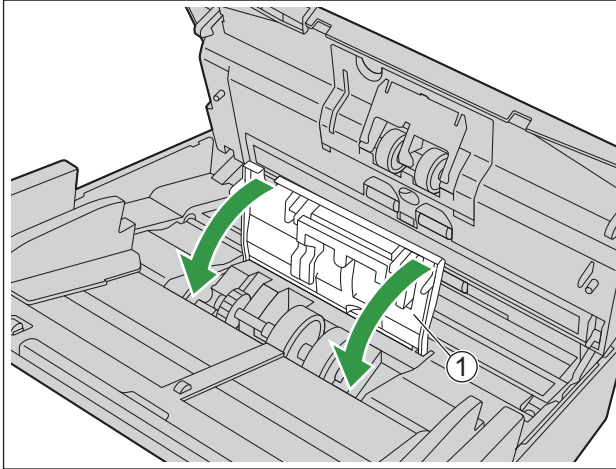

Notice

- Make sure to close both sides of the paper feed roller cover until they click into place.
- After installing the paper feed roller, confirm that the paper feed roller can rotate in the feeding direction.

15. Close the ADF door (page 32).

16. Turn on the unit's power (page 31).

17. After replacing the roller, set the After Replace Roller Counter to zero (0) (page 100).

Note

- If misfeeding or double feeding occurs after cleaning or replacing the rollers, the rollers may not be installed properly. Confirm the installation conditions again.

10.3.1 Clearing the Counter After Replacing the Rollers

After replacing the rollers, set the After Replace Roller Counter to zero (0) from the operation panel (page 25).

1. Press and hold the Skip/Menu button (▶|) for 1 second or more.
2. Use ▲ or ▼ of the cursor button to select "Counter".
3. Press the OK button to complete your selection.
4. Use ▲ or ▼ of the cursor button to select "Clear Replace Roller Counter".
5. Press the OK button to complete your selection.

11 Appendix

11.1 Available Functions When Scanning

The functions you can use when scanning differ depending on how you are using the scanner. For details, refer to the following table.

Note

- For details about the function names, refer to the help for Image Capture Plus, TWAIN, or ISIS.

Function name	Pull scan (Using Image Capture Plus, TWAIN, or ISIS) Push scan <ul style="list-style-type: none"> • USB mode • Network PC mode 	Push scan <ul style="list-style-type: none"> • Preset Scan mode (FTP server, shared folder, e-mail, Cloud, SharePoint)
Paper Source	Available	Available
Page Size	Available	Available
Image Type	Available	Available ¹
Resolution	Available	Available
Dynamic Threshold	Available	Available
Brightness	Available	Available
Contrast	Available	Available
Automatic Crop	Available	Available
Deskew	Available	Available
Rotate	Available	Available
Blank Page Removal	Available	Available
Noise Reduction	Available	Available
Smooth Background	Available	Available
Background Removal	Available	Available
Detect Double Feed	Available	Available
Halftone	Available	—
Area	Available	—
Long Paper	Available	—
Length Control	Available	—
Margin	Available	—
Sub Area	Available	—
Image Emphasis	Available	—
Chroma	Available	—

11.1 Available Functions When Scanning

Function name	Pull scan (Using Image Capture Plus, TWAIN, or ISIS) Push scan <ul style="list-style-type: none"> • USB mode • Network PC mode 	Push scan <ul style="list-style-type: none"> • Preset Scan mode (FTP server, shared folder, e-mail, Cloud, SharePoint)
Gamma	Available	—
Fit To Page	Available	—
Border Removal	Available	Available ²
Hole Removal	Available	Available ²
Drop Out	Available	—
Multi Color Drop Out	Available	—
White Level From Paper	Available	—
Automatic Separation	Available	—
Moire Reduction	Available	—
Double Exposure	Available	—
Color Matching	Available	—
Automatic Image Orientation	Available	Available ³
2-Page Separation	Available	—
Detect Dog-ear	Available	—
Barcode	Available	Available ³
Patchcode	Available	—
Auto Preview	Available	—
Auto Rescan	Available	—
Notification features	Available	—
Control Sheet	Available	—
Separation Sheet	Available	—
Searchable PDF output	Available	Available ³

¹ Multi Stream is not available.

² To use this feature, you need to set up the scan server.

³ To use this feature, you need to set up the scan server with option CD-ROM [KV-SS094].

11.2 Perform Network Settings with USB Connection

You can configure the network settings using Network Setting Tool with USB connection. For details about network-related settings, consult your network administrator.

11.2.1 Configuring wired LAN settings

1. Start Network Setting Tool.
 - Display the current settings.
2. Click [Date & Time], and then set the date and time. → [OK]
3. Click [Change], and then configure the following network settings. → [OK]

Item	Description
Host Name	Set the host name for the scanner.
DHCP	Enable (On) or disable (Off) DHCP.
AutoIP ^{*1}	Enable (On) or disable (Off) AutoIP. If DHCP is disabled, this setting cannot be changed.
IP Address	Set the IP address. If DHCP is enabled, the IP address will be set automatically and cannot be changed.
Subnet Mask	Set the subnet mask. If DHCP is enabled, this will be set automatically and cannot be changed.
Default Gateway	Set the default gateway. If DHCP is enabled, this will be set automatically and cannot be changed.
DNS Server 1	Set the primary DNS server. If DHCP is enabled, this will be set automatically and cannot be changed.
DNS Server 2	Set the secondary DNS server. If DHCP is enabled, this will be set automatically and cannot be changed.
WINS Server 1	Set the primary WINS server. If DHCP is enabled, this will be set automatically and cannot be changed.
WINS Server 2	Set the secondary WINS server. If DHCP is enabled, this will be set automatically and cannot be changed.

*1 When the IP address can not be acquired from the DHCP server, the following values are automatically set.

- IP Address: 169.254.1.0 - 169.254.254.255
- Subnet Mask: 255.255.0.0
- Default Gateway: 0.0.0.0

In this case, if the IP address has the same value as other devices, the unit can not be connected to the network. Check the DHCP server is running correctly.

Notice

Check the following if you cannot connect the unit to the network.

- If the LED (Orange) (①) of the LAN connector is not illuminated, confirm that the LAN cable is connected to the LAN connector of the unit correctly.
- If the LED (Green) (②) of the LAN connector is blinking, check the network settings using the Network Setting Tool.

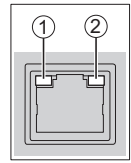

11.3 Check the Event Settings for Push Scan

Check the following if an application does not start up after being set in Scan Button Setting Tool.

1. Display the scan properties screen.
 - **If you are using Windows 10 / Windows 8 / Windows 7:**
[Control Panel] → [View devices and printers], right-click the scanner icon, and display the [Scan properties] screen.
 - **If you are using Windows Vista:**
[Control Panel] → [Scanners and Cameras], select the scanner icon, and then click the properties button.
2. Click the [Events] tab.
3. Check that Scan Button Setting Tool is selected as the program to start for each event.
 - If an application other than Scan Button Setting Tool is selected, change the application to Scan Button Setting Tool.
4. Click [OK].
5. Restart the computer.

11.4 Server Certificate

If you use HTTPS to access the scanner, a security alert will appear on the screen. To prevent the security alert from appearing, you must install the server certificate. We recommend using a server certificate that was issued by third-party signing organization (a certificate authority). For details, refer to "11.4.1 Installing a server certificate" (page 106).

You can also use a certificate issued independently by a non-authority or a self-signed certificate issued by the scanner. For details, refer to "11.4.2 Installing a self-signed certificate" (page 107).

11.4.1 Installing a server certificate

Creating a certificate signing request (CSR)

1. Launch Configuration Web.
 - For details, refer to "8.1 Launch Configuration Web" (page 66).
2. Open the [Network] tab.
3. Click [SSL/TLS].
4. In "Create CRT Key", click [Edit].
 - You can not create a CRT key if Self-signed Certificate or Security Certificate is enabled.
5. Set "CRT Key Length".
 - When using a server certificate, the permissible key length depends on the certificate authority. Please confirm beforehand.
6. Click [Submit].
 - Do not operate the browser until creation of the CRT key is complete. While the CRT key is being created, screen updates and network communication may be slow.
7. Click [Back].
8. In "Certificate Signed Request", click [Edit].
9. Edit the contents of "Certificate Signed Request".
10. Click [Submit].
11. Click [Save].
 - The certificate signing request (CSR) will be saved. You can obtain a server certificate with this CSR from a certificate authority.

Installing a server certificate

1. Launch Configuration Web.
 - For details, refer to "8.1 Launch Configuration Web" (page 66).
2. Open the [Network] tab.
3. Click [SSL/TLS].
4. In "Certificate Installation", click [Edit].
5. Click [Browse] in "File" and specify the server certificate file following the on-screen instructions.

Enabling SSL/TLS

1. Launch Configuration Web.
 - For details, refer to "8.1 Launch Configuration Web" (page 66).
2. Open the [Network] tab.
3. Click [SSL/TLS].
4. In "Setup", click [Edit].
5. Set "Service" to [On].
6. Click [Submit].
 - Turn the unit's power off and then on again.

11.4.2 Installing a self-signed certificate

1. Launch Configuration Web.
 - For details, refer to "8.1 Launch Configuration Web" (page 66).
2. Open the [Network] tab.
3. Click [SSL/TLS].
4. In "Create CRT Key", click [Edit].
 - You can not create a CRT key if Self-signed Certificate or Security Certificate is enabled.
5. Click [Submit].
 - Do not operate the browser until creation of the CRT key is complete. While the CRT key is being created, screen updates and network communication may be slow.
6. Click [Back].
7. In "Self-signed Certificate", click [Edit].
8. Click [Submit].
9. Click [Back].
10. In "Setup", click [Edit].
11. Set "Service" to [On].
12. Click [Submit].
 - Turn the unit's power off and then on again.

11.5 Import/Export

You can export the contents of the scanner's settings to a file. Also, you can import this file to the other scanners. You can set a password for this file. It is used for importing.

To export the settings

1. Launch Configuration Web.
 - For details, refer to "8.1 Launch Configuration Web" (page 66).
2. Open the [Administrator] tab.
3. Click [Import/Export].
4. In "Mode", select [Export].
5. Select the items you want to export.
6. Input a password (0 to 16 characters) for the file.
7. Click [Submit], and save the file according to the browser.

To import the settings

1. Launch Configuration Web.
 - For details, refer to "8.1 Launch Configuration Web" (page 66).
2. Open the [Administrator] tab.
3. Click [Import/Export].
4. In "Mode", select [Import].
5. Select the items you want to import.
6. Input the file name and password.
7. Click [Submit].

11.6 Backup/Restore

You can backup all the contents of the scanner's settings to a file. Also, you can restore the settings to the scanner. You can set a password for this file. It is used for restoring.

To backup the settings

1. Launch Configuration Web.
 - For details, refer to "8.1 Launch Configuration Web" (page 66).
2. Open the [Administrator] tab.
3. Click [Backup/Restore].
4. In "Mode", select [Backup].
5. Input a password (0 to 16 characters) for the file.
6. Click [Submit], and save the file according to the browser.

To restore the settings

1. Launch Configuration Web.
 - For details, refer to "8.1 Launch Configuration Web" (page 66).
2. Open the [Administrator] tab.
3. Click [Backup/Restore].
4. In "Mode", select [Restore].
5. Input the file name and password.
6. Click [Submit].

11.7 Factory Reset

This function will erase all of the settings in the scanner and initialize it to the factory default settings.

- This unit saves the information that you set, such as the network configuration, passwords, e-mail addresses, etc. To prevent leakage of your information, initialize the unit to the factory default settings before you discard or transfer the unit.
- You cannot restore the settings after Factory Reset. Keep a copy of all important data.
- If you forget the user name or password, you can reset the user name and password using Factory Reset. After Factory Reset, configure the scanner again.
- The following items are reset by "Factory Reset".
 - Function (page 70)^{*1}
 - Scan Settings (page 72)
 - Preset Scan (page 73)
 - Network (page 74)
 - Server (page 76)
 - Information Notification (page 78)
 - User Name / Password (page 79)

^{*1} "System Counter" is not reset.

1. Connect the unit to your computer via USB.
2. Start User Utility.
3. Click [Maintenance Setting].
4. Click [Factory Reset] and follow the on-screen instructions.

Note

- Resetting the current language during a factory reset is optional. If you choose to reset the language settings, the LCD display will prompt you to select a new language setting after the scanner restarts.

11.8 Troubleshooting

If a problem occurs while the scanner is being used, check the following items and check the scanner status on the LCD or in User Utility. If the unit still malfunctions, turn it off, unplug the power cord and call for service.

Symptom	Possible Cause	Remedy
The LED (Green) does not light when the unit's power is turned on.	The power cord is not plugged in.	Insert the power plug firmly.
The computer does not recognize the scanner. The scanner is not functioning correctly.	The scanner is not connected to the computer correctly.	Connect the USB cable or LAN cable correctly.
	The software is not installed correctly.	Uninstall the software from the computer (page 118), and then install the software again (page 21).
	The scanner is connected via USB hub.	Do not connect via USB hub.
	There is a problem with the cable.	If you are using a USB cable, be sure to use the included USB cable. If you are using a LAN cable, use a category 5 or enhanced category 5 cable or greater.
	The network-related settings are incorrect.	Check the network-related settings (page 103).
	The unit's power was turned off because no operations were performed for a certain period of time.	Turn on the unit's power (page 31).
Scan speed is slow.	The scanner is connected over a USB 1.1 connection.	Connect over USB 2.0, USB 3.0 or USB 3.1.
	In case of using this unit with a LAN connection, the scanning speed may be slower due to network traffic.	Consult your network administrator.
The document has been loaded on the feed tray, but the scanner does not start scanning.	The document is not loaded properly.	Load the document correctly (page 39).
	The sensor cannot detect the document as the edge of the document is curled.	Flatten the document (page 34) and load it again (page 39).
The documents are not fed one at a time, but in bunches.	The scanning method is set to manual.	Select automatic scanning using the manual feed selector (page 46).
A double feed is detected when scanning cards.	The cards are set in portrait orientation.	Either disable the double feed detection function or set the cards in landscape orientation.

11.8 Troubleshooting

Symptom	Possible Cause	Remedy
Paper jams occur frequently.	The document is wrinkled.	Smooth out the document.
	The rollers are dirty.	Clean the rollers (page 86).
	The document is not aligned correctly.	Realign the document (page 39).
	Too many sheets are set on the feed tray.	Remove sheets until the sheets on the feed tray are under the limit mark on the document guide.
Scanned documents have been rolled up in the exit tray area when using the exit guides.	The documents are curved or curled.	Scan the documents with the exit guides folded (page 39).
Double feeding occurs frequently.	The paper feed roller or double feed prevention roller is dirty.	Clean the paper feed roller or double feed prevention roller (page 86).
	The paper feed roller or double feed prevention roller have become worn down.	Replace the paper feed roller or double feed prevention roller (page 94).
	The double feed detectors are dirty.	Clean the double feed detectors (page 85).
	Right and left sides of the document to be scanned are not the same in height because of curling or folding.	Flatten the document (page 34) and load it again after reducing the number of sheets.
	The document is printed on an unsupported type of paper or thick paper.	Make a copy of the document on paper of a compatible type and thickness (page 33), and then scan the copy.
	The length of the paper is too short.	Make a copy of the document on paper of a compatible size (page 33), and then scan the copy.
	The document is not aligned correctly.	Realign the document (page 39).
	Too many sheets are set on the feed tray.	Remove sheets until the sheets on the feed tray are under the limit mark on the document guide.
	The double feed detectors are not adjusted properly.	Remove the documents, and then turn off/on the unit's power (page 31).

Symptom	Possible Cause	Remedy
Scanned image is skewed.	The document guides are not adjusted to the size of the document to be scanned, or the document to be scanned is set slanted on the feed tray.	Adjust the document guides properly to the size of the document to be scanned (page 39).
	Right and left sides of the document to be scanned are not the same in height because of curling or folding.	Flatten the document (page 34) and load it again after reducing the number of sheets.
The image of a scanned document is blank.	The document to be scanned was loaded upside down.	Load the documents with the surface to be scanned facing down.
Vertical streaks appear on the scanned document.	The scanning glasses are dirty.	Clean the conveyor and scanning glasses (page 84). The problem may also be resolved by using "Vertical Line Reduction" in User Utility. For details, refer to the User Utility help.
The scanning density is uneven.	The scanning glasses are dirty.	Clean the conveyor and scanning glasses (page 84). The problem may also be resolved by using "Vertical Line Reduction" in User Utility. For details, refer to the User Utility help.
The color of the scanned document is extremely different from the original document.	The settings of the computer monitor do not accurately reflect the color of the document.	Adjust the computer monitor settings.
	Depending on the documents scanned, the color of documents may not be scanned properly. For example, the color of a highlighter pen may be scanned lighter than it appears.	Setting the value for [Chroma] higher in the scanning conditions may solve this problem.
Dark spots or noise appear on the scanned documents.	The scanning glasses are dirty.	Clean the conveyor and scanning glasses (page 84).
There is noise or wave patterns (moire pattern) on the scanned image.	The scanning resolution settings, combined with patterns within the scanned image, may cause this problem.	Change the scanning resolution or turn the Moire Reduction function on, and perform scanning again. About Moire Reduction function, refer to the Image Capture Plus, TWAIN, or ISIS help.

11.8 Troubleshooting

Symptom	Possible Cause	Remedy
The sound made by paper being ejected is higher than usual when you scan short documents.	If the length of documents are less than about 148 mm (5.8 in.), feeding speed control will be activated for exiting documents; this is normal behavior.	—

If you still experience problems after following these suggestions, please contact our Technical Support Department at 1-800-726-2797 for further assistance. (U.S.A. only)

11.9 Error Codes and Error Messages

Error codes corresponding to the scanner status are displayed on the LCD.

For details about the error codes and messages, check in User Utility.

If you cannot solve the problem by the following instructions, consult your administrator.

Error Code	Cause	Remedy
U11 U12	The paper has jammed in the feed tray area.	Open the ADF door, and remove the paper.
	The sensors are dirty.	Clean the sensors.
U16	The paper has jammed in the exit tray area.	Open the ADF door, and remove the paper.
	The sensors are dirty.	Clean the sensors.
U18	Paper has been left in the scanner.	Open the ADF door, and remove all the paper left inside.
	The sensors are dirty.	Clean the sensors.
U23	A double-feed error has occurred.	Open the ADF door, and remove the jammed paper.
U30	The ADF door is open.	Close the ADF door.
C00	The scanner is offline.	Check the connections of the LAN.
C10	The scanner cannot communicate with the computer.	Check the connection with the computer.
C20	The IP address of the server or the network configuration is incorrect.	Check the following configurations depending on the destination. – FTP Server – Shared Folder – SMTP Server
	The server is down.	Check the status of the server.
C21	The server name or network configuration is incorrect.	Check the following configurations depending on the destination. – FTP Server – Shared Folder – SMTP Server
	The server is down.	Check the status of the server.
C22	Login name or password of the server is incorrect, or you do not have permission to log in to the server.	Check the following configurations depending on the destination. – FTP Server – Shared Folder – SMTP Server

11.9 Error Codes and Error Messages

Error Code	Cause	Remedy
C23	The path of the FTP server or Shared folder is incorrect.	Check the following configurations depending on the destination. – FTP Server – Shared Folder
C24	Network data transfer was aborted.	Check the connections of the LAN.
	The e-mail server configuration requires authentication.	Check the configurations of the SMTP server.
	Data could not be sent to an FTP server or a shared folder. The destination may be read only, or the disk may be full.	Consult your network administrator.
C30	The size of the e-mail exceeds the limit (page 120).	Change the size limit for e-mail. For details, refer to "SMTP" (page 76).
		Change to a lower resolution for scanning, or reduce the number of documents.
Fxx	A system error has occurred.	Turn the power off, and then turn it on again (page 31). If the problem is still not resolved, turn off the power, unplug the power cord, and contact your dealer.

The following error codes relate to "Scan Server" or Network PC mode.

Error Code	Cause	Remedy
C60	The scanner cannot communicate with the scan server.	Check scan server's login status and check the connection with the scan server.
		If the host name is set as the computer name, try to input the IP address instead.
		Check that Image Capture Plus (version 3.7 or later) is installed on the scan server.
C61	Image Capture Plus cannot be used with the specified scanner settings to scan via the Scan Server. To use the specified settings, content from the server option CD-ROM must be installed and set up the scan server.	Purchase the server option CD-ROM (Product number: KV-SS094).
C62	The scan server registered to the scanner cannot be used.	Use the Scan Server Setting Tool to configure the server.
C63	Image Capture Plus cannot be used with the specified scanner settings. To use the specified settings, optional CD-ROM content must be installed.	Purchase the optional CD-ROM (Product number: KV-SS092 or KV-SS093).
C70	Image Capture Plus is in use.	Wait a moment and try again.

Error Code	Cause	Remedy
C71	Scan server is currently processing another job.	Wait a moment and try again.
C72	An error occurred while scanning with Image Capture Plus.	After initializing Image Capture Plus, click [Help] - [Display Logs] to check the error details.
C73	An error occurred while transferring via Image Capture Plus.	After initializing Image Capture Plus, click [Help] - [Display Logs] to check the error details.
C74	The size of the e-mail exceeds the limit with Scan Server scanning (page 120).	Change the limit of e-mail size. For details, refer to "SMTP" (page 76).
		Change to a lower resolution for scanning, or reduce the number of documents.
C80	The size of image data exceeds the limit (page 120).	Change to a lower resolution for scanning, or reduce the number of documents.
C81	The number of scanned pages exceeds the limit (page 120).	Reduce the number of documents.

11.10 Uninstalling the Software

If you want to remove the software that is installed on your computer, follow the procedure below to uninstall it.

1. In [Control Panel], open [Uninstall a program].
2. Uninstall the following software programs.
 - Export Import Tool
 - IDREngine
 - Image Capture Plus
 - KV-S1058Y / KV-S1057C MK2 / KV-S1028Y / KV-S1027C MK2 ISIS Driver
 - MCD
 - OCREngine
 - Panasonic Scanner Manuals
 - Panasonic Document Scanner Device Driver
 - Panasonic Document Scanner TWAIN Driver
 - Panasonic Scanner User Utility
 - Scan Button Setting Tool
3. Follow the instructions on the screen.

11.11 Repacking Instructions

It is highly recommended that you keep the original carton and *ALL* packing materials. If you need to transport or ship the scanner, please follow these instructions.

Note

- Improper repacking of the scanner may result in a service charge to repair the scanner.
- Please use the original carton and all of the original packing materials.
- The scanner should be handled in the correct (horizontal) position.

Required Materials

- Original scanner carton and packing materials
 - Shipping tape and scissors
1. Turn the unit OFF (page 31), unplug the power cord and disconnect the USB cable and LAN cable.
 2. Pack the scanner.

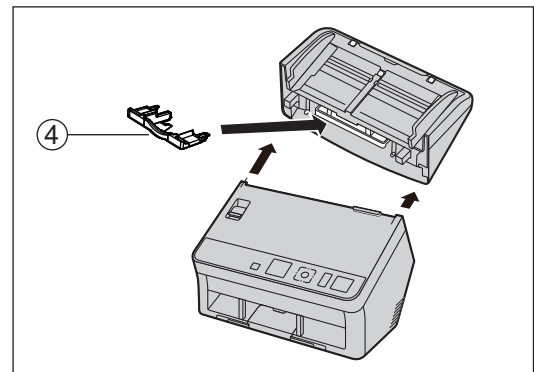
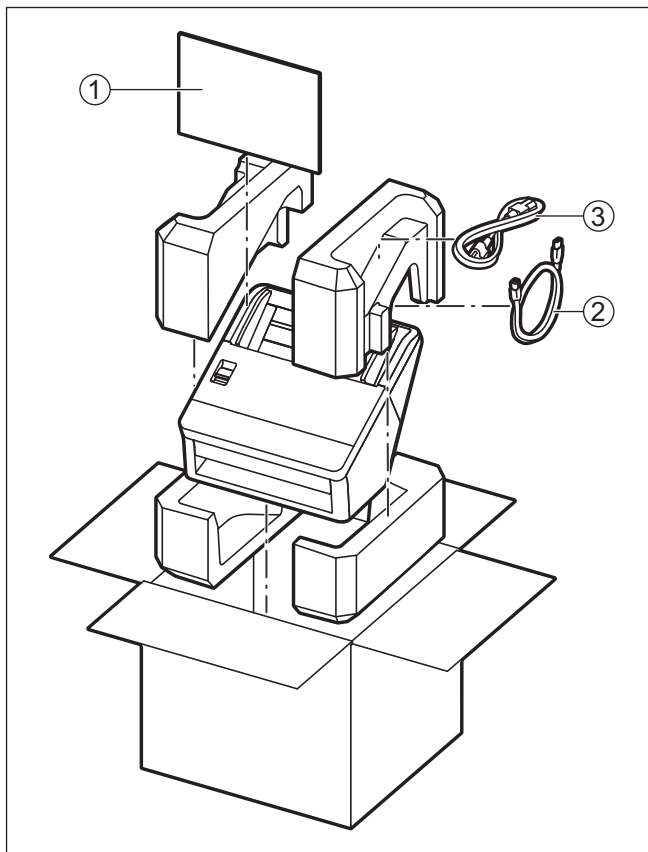

- ① Quick Installation Guide and Software / Manual CD-ROM
- ② USB cable
- ③ Power cord
- ④ Mixed batch card guide

11.12 Specifications

Scanning

Item		KV-S1058Y KV-S1057C M2 KV-S1057C J2 KV-S1057C B2	KV-S1028Y KV-S1027C M2 KV-S1027C J2 KV-S1027C B2
Scanning face		Duplex	
Scanning method		1 line Color CIS (300 dpi/600 dpi)	
Scanning speed ^{*1} • A4 / Portrait • Binary / color • 200 dpi, 300 dpi	ADF (Simplex)	70 pages/min.	45 pages/min.
	ADF (Duplex)	140 images/min.	90 images/min.
Scanning resolution ^{*2}		100 dpi – 600 dpi (1 dpi step), 1,200 dpi (Interpolated) Optical: 300 dpi / 600 dpi (Automatic switch)	
Paper size ^{*3}	Width × Length	When feeding one sheet: 48 mm × 54 mm – 216 mm × unlimited (1.9 in. × 2.1 in. – 8.5 in. × unlimited) ^{*4} When feeding multiple sheets: 48 mm × 54 mm – 216 mm × 356 mm (1.9 in. × 2.1 in. – 8.5 in. × 14 in.)	
	Thickness	Paper: 0.04 mm – 0.5 mm (1.6 mils – 19.7 mils) Bound documents: 4 mm (157.5 mils) (including carrier sheet) Note: 1 mil = 0.001 in.	
	Weight	20 g/m ² – 413 g/m ² (5 lb. – 110 lb.)	
Card ^{*5}	Format	ISO format	
	Size	85.6 mm × 54 mm (3.4 in. × 2.1 in.)	
	Thickness	0.76 mm (30.0 mils) Embossed card up to 1.4 mm (55.1 mils.)	
	Feed capacity	3 cards on the feed tray or on the mixed batch card guide	
Passport ^{*6}	Width	130 mm (5.1 in) or less	
	Length	188 mm (7.4 in) or less	
	Thickness	4.0 mm (0.15 in) or less (including carrier sheet)	
Feed capacity		100 sheets (80 g/m ² [21 lb.] High-quality woodfree paper) ^{*7}	
Roller replacement ^{*8}		250,000 sheets	
Image data size using push scan	Shared Folder	Up to 512 MB in total or 999 pages	
	FTP		
	Email	Up to 20 MB in total (including the header and e-mail message) or 999 pages	

^{*1} The scanning speed is the maximum speed of the scanner hardware. It does not include software processing time, data transfer time, etc. The scanning speed measurement is based on Panasonic's measuring method.

- *2 When scanning a document larger than A5 size at high resolutions over 600 dpi, the scanning may fail due to insufficient memory.
- *3 For details, see "6.2.1.1 Compatible Paper" (page 33).
- *4 Using "Long Paper", you can scan a long document to a series of split scanned images. For details about "Long Paper", refer to the Image Capture Plus, TWAIN, or ISIS help.
- *5 For details, see "6.2.1.2 Compatible Card" (page 35).
- *6 Use the carrier sheet (KV-SS077) to scan passport (page 36).
- *7 Paper less than 100 mm (3.9 in.) long or legal size paper: 75 sheets
- *8 For details, see "10.3 Replacing the Rollers" (page 94).

General

Item		KV-S1058Y KV-S1057C M2 KV-S1057C J2 KV-S1057C B2	KV-S1028Y KV-S1027C M2 KV-S1027C J2 KV-S1027C B2
External dimensions (Width × Depth × Height)		300 mm × 272 mm × 238 mm (11.8 in. × 10.7 in. × 9.4 in.)	
Weight		4 kg (8.8 lb.)	
Power requirements ^{*1}		AC 100 – 127 V, 50/60 Hz, 0.8 A AC 220 – 240 V, 50/60 Hz, 0.4 A	
Power consumption	Scanning	36 W or less	
	Ready	8 W or less	
	Sleep	2 W or less (USB connection) 2 W or less (LAN Connection) ^{*2}	
	Power OFF	AC 100 – 127 V: 0.3 W or less AC 220 – 240 V: 0.5 W or less	
Operating environment		Temperature: 5 °C – 35 °C (41 °F – 95 °F) Humidity: 20 % – 80 % RH	
Storage environment		Temperature: -10 °C – 50 °C (14 °F – 122 °F) Humidity: 8 % – 75 % RH	
Interface		USB 3.1 Gen1 (backward compatible) LAN (10Base-T / 100Base-TX / 1000Base-T) ^{*3}	
Recommended web browser		Internet Explorer 11 Mozilla Firefox (latest version) Google Chrome (latest version)	

*1 The power requirements differ depending on the country/area. Do not use a power source that does not meet the power source specifications marked on the unit. The power source specifications of this unit are listed on the rating name plate.

*2 If connected to a network device (hub, router, etc.) that supports IEEE802.3az.

*3 To assure continued emission limit compliance, use only shielded LAN cable. The cable should be a CAT 5 (Category 5) or higher for 10Base-T / 100Base-TX, or CAT 5e (Enhanced Category 5) or higher for 1000Base-T.

